



# BALL **DISPENSER**



ULTIMA 8 | ULTIMA 12 | ULTIMA 20 | ULTIMA 45

# CONTENTS

<b>1</b>	<b><u>General information</u></b>	<b>4</b>
1.1	Preface	4
1.2	EC Declaration of Conformity	5
1.3	Description	6
1.3.1	Ball Dispenser	6
1.3.2	Ball Management System	6
1.4	Identification	6
1.5	Technical specifications	7
<b>2</b>	<b><u>Safety</u></b>	<b>8</b>
2.1	General	8
2.2	Conformity with mandatory requirements	8
2.3	Remaining risks	8
2.4	Authorised use	9
2.5	Unauthorised use	9
2.6	Emergencies	10
2.6.1	Fire	10
2.7	Operational reliability	10
<b>3</b>	<b><u>How to use the Ball Dispenser</u></b>	<b>11</b>
3.1	Necessary qualifications	11
3.2	BA-99 Control System	11
3.2.1	Introduction	11
3.2.2	Getting started	12
3.2.3	Adjustment of conveyor belt speed	12
3.2.4	Adjustment of photocell	13
3.3	Payment Methods and Prices	14
3.3.1	Range Servant® Tokens	14
3.3.2	Mechanical Coin Control	15
3.3.3	Electronic Coin Control Cashflow 340	17
3.3.4	Manual magnetic card reader (EMC-30)	19
<b>4</b>	<b><u>Design and function</u></b>	<b>20</b>
4.1	General	20
4.1.1	Machine exterior	21
4.1.2	Machine interior	22
4.2	Description of components	23

4.2.1	Grid	23
4.2.2	Payment Methods	23
<b>5</b>	<b><u>Maintenance</u></b>	<b>24</b>
5.1	General	24
5.2	Periodical maintenance	24
5.3	Maintenance intervals and instructions	24
5.4	Troubleshooting and repair	26
5.5	Function test	27
<b>6</b>	<b><u>Installation</u></b>	<b>28</b>
6.1	Factory testing and configuration	28
6.2	Installation of the ball dispenser	28
6.3	Installation – Wiring Diagram	31
6.3.1	Wiring Diagram for the connection of BA-99 to the Ball Dispenser	31
6.3.2	Wiring of Payment Systems	32
6.3.3	Cables	36
<b>7</b>	<b><u>Spare parts</u></b>	<b>37</b>
7.1	External	37
7.2	Control box	38
7.2.1	Control box door with mechanical coin control	39
7.2.2	Control box door with electronic coin control	39
7.2.3	Inner side of the control box door with mechanical coin control	40
7.2.4	Inner side of the control box door with electronic coin control	41
7.2.5	Inside the control box, EMC-30 card reader	42
7.3	Internal	43
7.3.1	Grid	44
<b>8</b>	<b><u>Retailers and representatives</u></b>	<b>45</b>
8.1	Head Office	45
8.2	Your Sales Representative	45

Title:	Br10ultima-E.doc
Prepared by:	Johan Carlsson
Date:	2010-04-15
Number of words:	6656
Version:	5

# 1 General information

## 1.1 Preface

We congratulate you to your new Range Servant machine. You have made a good choice! Not only have you chosen an excellent state-of-the-art Ball Dispenser with little demands on maintenance but you have also chosen quality. Quality is ensured with the help of modern production techniques, carefully chosen materials and the responsible workmanship of our staff.

This User's Manual contains all the information necessary to fully understand the maintenance and operation of the machine.

The machine may be equipped with another a bit more complicated control system referred to as the Select System, in which case some of the information given herein does not apply. Please then refer to the separate manual for the Select System.

**Study the User's Guide carefully before using the machine.** If these instructions are not followed, persons using the machine might be injured or the equipment itself be damaged. In many cases, following the instructions is a necessary condition for Range Servants' warranty to be applicable. Every person operating the machine must read these instructions.

No part of this publication may be reproduced without the written authorisation of Range Servant.

We offer a limited one-year warranty on our Ball Dispensers. This does not include payment systems and normal wear and tear. Study the warranty conditions carefully and keep them in a safe place. If you have any questions, or if problems should arise, please contact your Range Servant representative.

### **ONE-YEAR WARRANTY**

Range Servant AB hereby undertakes to provide a warranty on material and function on the RANGE SERVANT dispenser for one year from the date of delivery. The guarantee does not cover payment systems and wearing parts. This engagement applies to repaired or replaced components for a period of three months. This undertaking only applies to the original purchaser. It also applies only to shortcomings of those parts, which the manufacturer verifies after due inspection. Repairs or replacement of parts may only be carried out by a representative authorised by the manufacturer. The manufacturer also guarantees that the equipment delivered matches the product description supplied. **THE UNDERTAKINGS SPECIFIED IN THIS AGREEMENT CONSTITUTE THE MANUFACTURER'S SOLE OBLIGATION TOWARDS THE PURCHASER. THE MANUFACTURER IS IN NO WAY RESPONSIBLE FOR ANY UNDERTAKINGS OUTSIDE THE FRAMEWORK OF THIS WARRANTY CERTIFICATE.** Neither is the manufacturer responsible for any undertakings given by any outside person during the sales negotiations. The warranty agreement does not apply to equipment that has been repaired or replaced by persons/companies not authorised by the manufacturer. The manufacturer's warranty undertaking does not apply if the equipment is used incorrectly, if it has been damaged through improper maintenance or accidents or if it has been handled in a way not specified in the manual which is supplied with the dispenser upon delivery. The manufacturer is also free from financial liability for any type of injury that may arise in connection with the sale and repair of the equipment and from injuries to third parties in conjunction with its use.

## 1.2 EC Declaration of Conformity

In accordance with the Machine Directive 89/392/EEC, annex IIA.

**The Manufacturer:** **RANGE SERVANT<sup>®</sup>**  
Range Servant AB  
Skallebackavägen 11  
SE- 302 41 HALMSTAD  
Sweden

**The Representative:**  
(To be filled out by a representative established within the EU)

.....  
Company  
.....  
Address  
.....  
Telephone

**Declare that:** Ball Dispenser .....  
Machine  
.....  
Type  
.....  
Serial no., manufacturing no. etc.

A) is in conformity with Council Directive 89/392/EEC of 14 June 1989 concerning approximation of the laws of the Member States relating to machines in particular as referred to in Annexe I to this Directive concerning essential health and safety requirements in connection with the design and manufacture of machines, as amended by Council Directive 91/368/EEC of 20 June 1991 on the amendment of Directive 89/392/EEC concerning approximation of the laws of the Member States relating to machines;

B) (if applicable) are manufactured in accordance with the following regulations, directives etc.: .....

C) (if the requirements under A have been fulfilled) that the harmonised standards 292-1, 292-2 and 292-2A (or parts thereof) have been applied

D) (if applicable) are manufactured according to the following national standards and technical specifications: .....

Halmstad, .....  
Date

Elvis Knez .....  
President Signature

## 1.3 Description

### 1.3.1 Ball Dispenser

The Ball Dispenser can be used either as a stand-alone machine or it can be integrated into a complete, automated system - the Range Servant Ball Management System.

The user-friendly ball dispensers from Range Servant are designed to accept different types of payment and to deliver, quickly and consistently, the exact number of balls. Prices are differentiated and several payment methods can be used in parallel. The number of dispensed balls per payment can be easily changed by the user himself. The balls are handled with care and only undamaged and clean balls are delivered to the player.

### 1.3.2 Ball Management System

Range Servant can deliver a complete, flexible Ball Management System adaptable to any kind of driving range requirements. The Ball Dispenser can be combined with the work-efficient, environment friendly Ball Washer. The Ball Washer in turn can be connected to the Elevator, the Conveyor Belt or the Blower for the transport of clean, undamaged balls from Washer to Dispenser. The system also includes a Ball Picker machine picking up used balls from all over the driving range. Thus the circle is closed and manual work reduced to a minimum.

By applying our extensive know-how to the specific problems of every driving range we are able to offer tailor-made solutions.

## 1.4 Identification

When contacting Range Servant, please identify your machine with the help of the information contained in the identification plate. The identification plate is well visible and firmly attached and contains the following information:

- Name and address of the manufacturer
- CE-marking
- Designation of series or type of machine
- Serial no., if any
- Year of manufacture

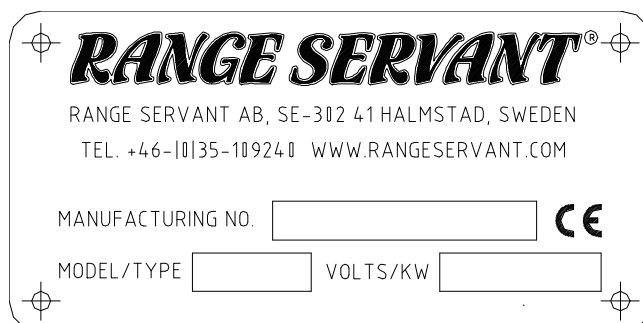

Fig. 1: Product identification plate

## 1.5 Technical specifications

General	Ultima-8	Ultima-12*	Ultima-20*	Ultima-45*
Capacity [balls]	8000	12000	20000	43000
Capacity [balls/h]	25000	25000	25000	25000
Settings [balls/ payment]	1-999	1-999	1-999	1-999
<b>Dimensions:</b>				
Height [mm] /([in])	1330 (52.4)	2056 (80.9)	2056 (80.9)	2056 (80.9)
Height open lid [mm] /([in])	1790 (70.5)	-	-	-
Width [mm] /([in])	1012 (39.8)	1012 (39.8)	2022 (79.6)	2022 (79.6)
Depth [mm] /([in])	760 (29.9)	760 (29.9)	760 (29.2)	1520 (59.8)
Weight, with balls [kg]	462	648	1112	XX
Weight, without balls [kg]	84	89	173	249
<b>Electric system:</b>				
Mains voltage [V, 50/60 Hz]	230/115	230/115	230/115	230/115
Control voltage [V, DC]	12 and24	12 and24	12 and24	12 and24
Effect, feeding motor [W]	17.4	17.4	2x17.4	2x17.4
<b>Operating Conditions:</b>				
Operating Temperature [°C] /([°F])	+2 - +50 (+35- +122)			

\* Ball Washer and elevator are not included

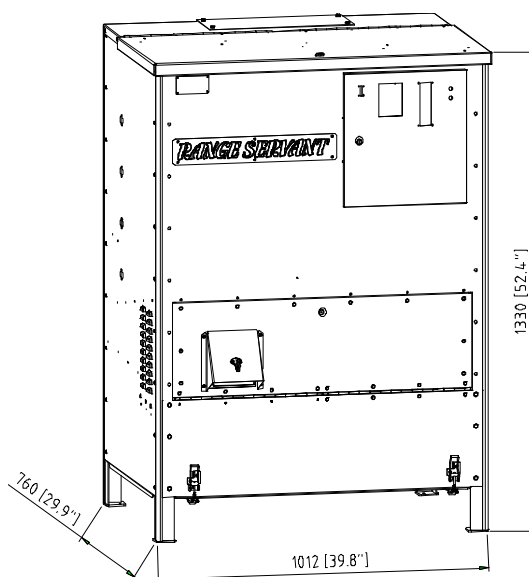

Fig. 2: Ball Dispenser Ultima-8.

The level of airborne noise has been measured for an identical machine under normal operating conditions.

The values indicate the sound pressure level measured 1 m from the sides of the machine and 1,6 m from the floor or access platform.

Sound pressure at the machine (dB, Lin)	XX	XX	XX	XX
Sound pressure at the machine (dB, A)	XX	XX	XX	XX

The manufacturer reserves the right to alter any details of the products without prior notice.

Patents: AU 2445699, USA 6371330, CN 99803416.9, HK 01104534.4

Patent applications: EUROPE 99903992.8, CA 2318910, SE 9800187-8

## **2 Safety**

### **2.1 General**

Safety measures are a combination of measures taken by the manufacturer when designing and building the machine and measures that have to be taken by the user.

The machine has been designed to function for its intended purpose. It has been designed and manufactured in such a way that configuration and maintenance can take place with the least possible risks to the operator, provided such work is carried out according to the instructions laid down in the User's Manual.

The objective of the safety measures is to eliminate all accident hazards during the operational life of the machine which also includes the assembly and dismantling of the machine, including any hazards arising as a consequence of such abnormal circumstances as can be anticipated.

Accessories and spare parts that have not been approved by Range Servant can lead to personal injuries and/or equipment damage and affect the operational reliability of the machine. For the sake of safety you should therefore exclusively use accessories and original Range Servant spare parts recommended by Range Servant.

Such accessories and spare parts are specially intended for the machine and are approved by us with regard to safety.

All Range Servant retailers keep accessories and spare parts at your disposal along with competent advice. They also have the technical qualifications necessary for installing your machine and are informed about what technical changes are authorised.

Damage caused by the use of accessories and spare parts not having been approved by Range Servant and damage due to unauthorised technical modifications are not covered by the warranty obligation.

### **2.2 Conformity with mandatory requirements**

The Range Servant ball management machines fulfil the personal safety requirements of the EU Machine Directive 89/392/EEC as amended by Directives 91/368/EEC, 93/44/EEC and 93/68/EEC, with a special reference to Annex I of the Directive concerning essential health and safety requirements in connection with the design and manufacture of machines, as amended by Directive 91/368/EEC. Furthermore the harmonised standards 292-1, 292-2 and 292-2A (or parts thereof) have been applied.

The electrical equipment fulfil the safety provisions laid down in the EU low voltage directive 73/23/EEC, as amended by directive 93/68/EEC.

### **2.3 Remaining risks**

There are warning signs serving as a reminder and warning to the user of any remaining risks, i.e. risks that we have not been able to eliminate, or sufficiently minimise, in our design and against which technical safety measures do not provide complete, or sufficient, protection. The warning signs shall be written in the local language and, on request, in the language understood by the respective operator. The signs are yellow with black characters. They are big enough to be readable from a distance of three meters.





Fig. 3: Warning signs on front hatch

- Always disconnect the power supply to the machine before carrying out maintenance or service work. The mains switch is located in the control box in the lower right hand corner of the printed circuit board.

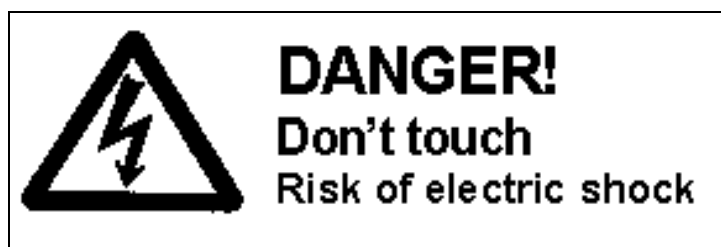

Fig. 4: Warning signs in control box

- Never touch the circuit board or other electrical components in the control box. They can be current conducting and cause injury to person and/or equipment damage
- Mechanical or electrical alterations may only be undertaken in consultation with Range Servant.

## 2.4 Authorised use

The ball-dispensing machine may only be used for the distribution of golf balls. For the machine to operate properly, the balls must be clean and undamaged or else they may get stuck and cause machine failure.

Distribution of balls may only start provided the machine has been installed according to the instructions contained in this Manual.

## 2.5 Unauthorised use

Using accessories or spare parts not recommended by Range Servant might cause personal injury and/or equipment damage and affect the operational reliability of your ball dispenser. For safety reasons, use only those components recommended by us. They are intended for your machine, they have been chosen for safety reasons and they are approved by the manufacturer.

Damage caused by the use of accessories and spare parts not having been approved by Range Servant or damage due to unauthorised technical changes are not covered by the warranty obligation.

## 2.6 Emergencies

### 2.6.1 Fire

Water shall be used as an extinguisher in the event of fire, except if the fire is located in the electric equipment, where a carbon dioxide extinguisher must be used.

## 2.7 Operational reliability

For trouble-free operation and long service life the instructions below should be followed:

- Place the ball-dispensing machine on a firm and level surface.
- Place the machine under cover so that only the front is accessible to members of the public. If the machine is card-operated it must stand under cover for the warranty to apply.
- Never strain the machine by loading it with more balls than recommended. The loading capacity for your machine is stated in the Technical Specifications at the end of the Manual.
- The machine should be connected to its own wall socket to prevent interference with its electronic system.
- Make sure that the electric box is always properly shut and covered when rinsing the machine. Moisture and water can damage the electrical components.
- When cleaning inside the dispenser never spray water directly onto the electric motor.

# 3 How to use the Ball Dispenser

## 3.1 Necessary qualifications

Due to the complex design and operation of the machine the person carrying out service and maintenance work must have the necessary qualifications. He is required to have attended a training course, in the form of a comprehensive study of the User's Manual, followed by a written statement to the fact that he has well understood its contents.

If the person has to be absent from work for more than three months, training has to be repeated.

## 3.2 BA-99 Control System

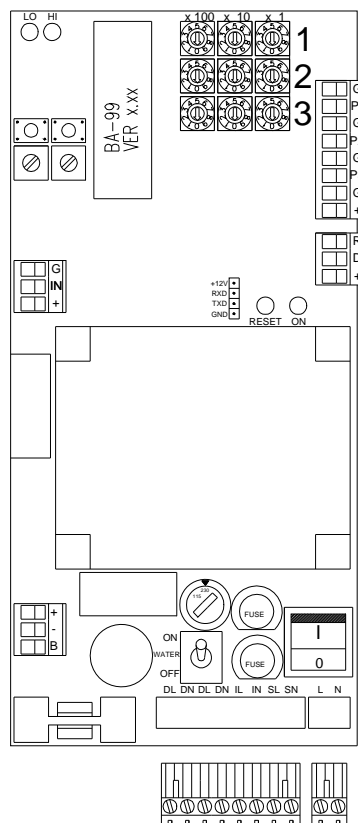

Fig. 5: BA-99 Control System

### 3.2.1 Introduction

The BA-99 system has three payment channels marked P1-P3 allowing the user to choose between three different amounts of balls to be dispensed ranging from 1-999. The desired amount is selected with the help of the nine knobs located to the left of the terminal block G – P1-P3. More details are given in the following chapter “Getting started”.

Payments can also be made during the dispensing process and will then be accumulated. A green LED marked ON is lit to indicate that power is on and a red LED marked DEP to indicate that payment has been registered and that the machine is

prepared to dispense balls. The system is also equipped with a small circuit card consisting of two LED's , a green and a red one, giving continuous information to the user. Green LED indicates that mains supply is on and red that payment has been made and that machine is in the process of dispensing.

### 3.2.2 Getting started

You can decide yourself how many balls you wish the machine to dispense per payment. The Ball dispenser accepts different payment methods and you are free to decide whether the machine shall make the same number of turns for all the different payments methods or not.

Connect the Ball Dispenser to the 230 VAC mains supply.

Adjust the ball dispensing knobs for the respective payment channel according to wish. Make your payment and check that the correct number of balls are dispensed. The machine dispenses balls at two different speeds – low and high. Dispensing starts at low speed, which allows for the conveyor belt to start running, and then continues at high speed. When there are only five balls left, the speed is again reduced to allow for the conveyor motor to stop at the right point preventing too many balls to be delivered. If you wish to adjust the speed of the conveyor belt, see the following chapter "Adjustment of conveyor belt speed".

Example:

#### Payment channel 1

23 Balls      x 100 = 0  
                   x 10 = 2  
                   x 1 = 3

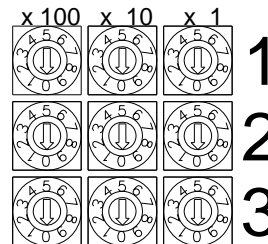

#### Payment channel 2

54 Balls      x 100 = 0  
                   x 10 = 5  
                   x 1 = 4

#### Payment channel 3

128 Balls     x 100 = 1  
                   x 10 = 2  
                   x 1 = 8

### 3.2.3 Adjustment of conveyor belt speed

The control card BA-99 is equipped with two knobs for adjustment marked HI and LOW as well as with two micro-switches that are located on the upper left side of the card. Press the micro-switch corresponding to either adjustment knob HI or LOW; the conveyor belt starts moving. Use a small screw driver to adjust the speed. LOW regulates the starting speed and the dispensing speed for the last five balls. HI regulates the normal dispensing speed. The LED marked STB on the photocell located above the conveyor belt shall be burning with steady light and the LED marked OP.L shall blink with each detected ball.

### **3.2.4 Adjustment of photocell**

The photocell is the component detecting the balls and signalling to the control system that the correct number of balls have been dispensed.

The photocell sends a red signal indicating where the balls are detected.

The photocell is adjusted as follows:

- Place a ball on the highest point of the conveyor belt. Make sure it is in line with the photocell and that the red ray of light from the photocell hits the ball at a point about 2/3 of the height of the ball.
- Move the ball sideways, all the while checking that the two LED's – STB and OP.L - of the photocell burn with steady light.
- Start dispensing and check that OP.L blinks with each detected ball.

STB = Stability LED means that the reflecting light is sufficient for detection.

OB.L = Operating LED means detection of an object.

### 3.3 Payment Methods and Prices

The Ball Dispenser is equipped with an operating panel where the customer can select the desired payment method. The panel contains two LED's, openings for coins or tokens, and a slot for magnetic cards or bill scanner.

The ball dispenser is also compatible with the Select.Lite™ software. Select.Lite™ is a complete and user-friendly front end for managing and controlling a ball management system. The payment methods available for the Select.Lite™ are the Select Members Card (MiFare), bar codes and tokens.

#### 3.3.1 Range Servant® Tokens

Range Servant® has 16 different types of tokens for use in the Range Servant® mechanical token acceptor.

**Token types:** RS- I to RS-IX, RS-A to RS-H

There are also two types of tokens for use in electronic coin acceptors.

**Token types:** RS-90, RS-91

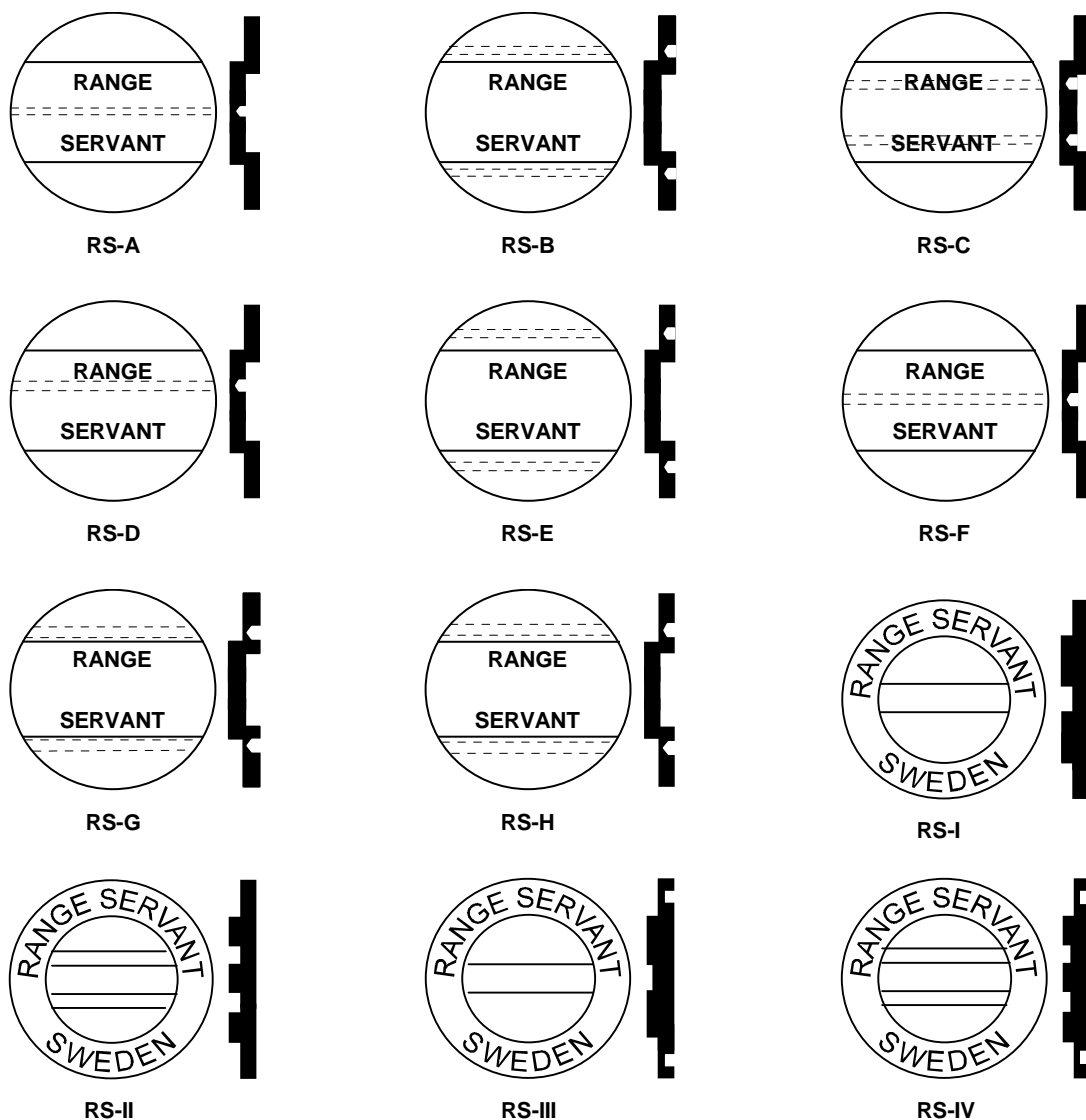

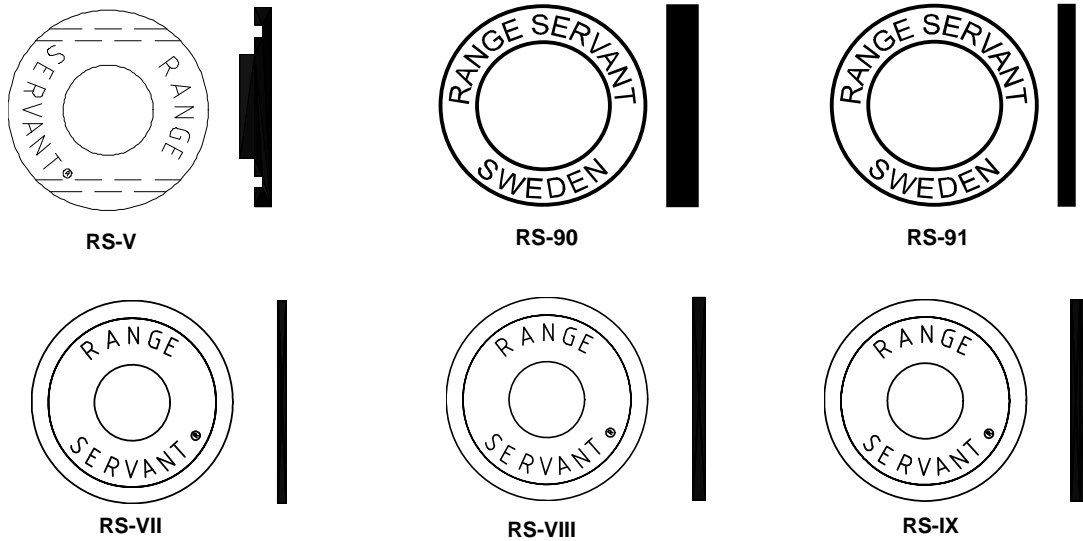

### 3.3.2 Mechanical Coin Control

Mechanical Coin control for one or two coins.

When a two coin control has been installed, this also includes a so called adding circuit card.

This card allows for prices that are higher than the coin value.

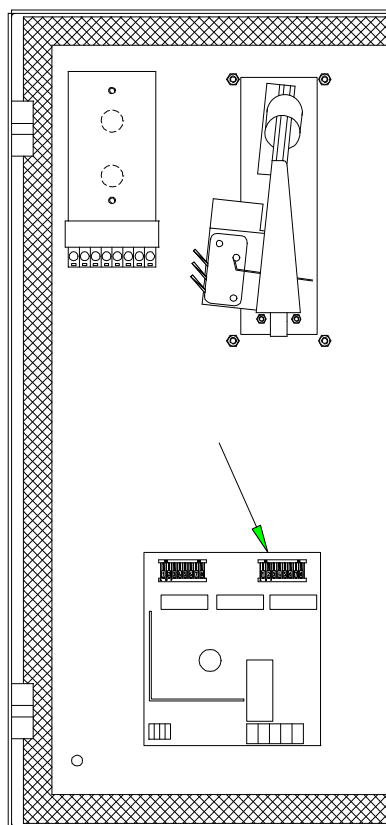

Figure 6: Mechanical coin control

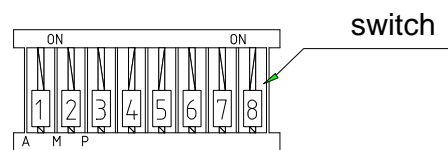

Figure 7: DIP switches

The adding circuit card (no. 107810) contains two 8-position DIP-switches marked DIP 1 and DIP 2 and two cable contacts.

The internal relation between the coins is set with the help of the DIP1 (switches 1-4).

The coin with the lowest value is always given value 1. The next setting determines how many times coin 2 is bigger than coin 1.

- 1-2 relation (switch 2 ON)
- 1-5 relation (switch 1+3 ON)
- 1-10 relation (switch. 2+4 ON)

Relay output port (1 sec. impulse output) DIP 1 switch 7+ 8 ON.

The price is set and modified by changing the position of the switches on DIP 2. The value is binary which means that:

Switch	1 represents	1 x the smallest coin
	2 represents	2 x the smallest coin
	3 represents	4 x the smallest coin
	4 represents	8 x the smallest coin
	5 represents	16 x the smallest coin
	6 represents	32 x the smallest coin
	7 represents	64 x the smallest coin
	8 represents	128 x the smallest coin

The switches can be variously combined to obtain prices ranging from the biggest to the smallest coin.

Example 1: The smallest coin is 5 SEK and the biggest 10 SEK.  
 You wish to obtain a price of 25 SEK.  
 Set switch 1 (=5 SEK) and 3 (=20 SEK) in the ON position.

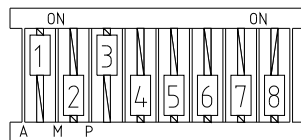

$$5+0+20+0=25$$

Example 2: The smallest coin is 5 SEK and the biggest 10 SEK.  
 You wish to obtain a price of 10 SEK.  
 Set switch 2 (=10 SEK) in the ON position.

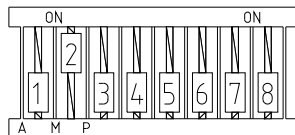

$$0+10+0+0=10$$



### 3.3.3 Electronic Coin Control Cashflow 340

The electronic coin control can be programmed for up to twelve different types of coins or ten coins plus the two electronic tokens RS-90 and RS-91.

**(In use from 970801 Mars® model Cashflow 340)**

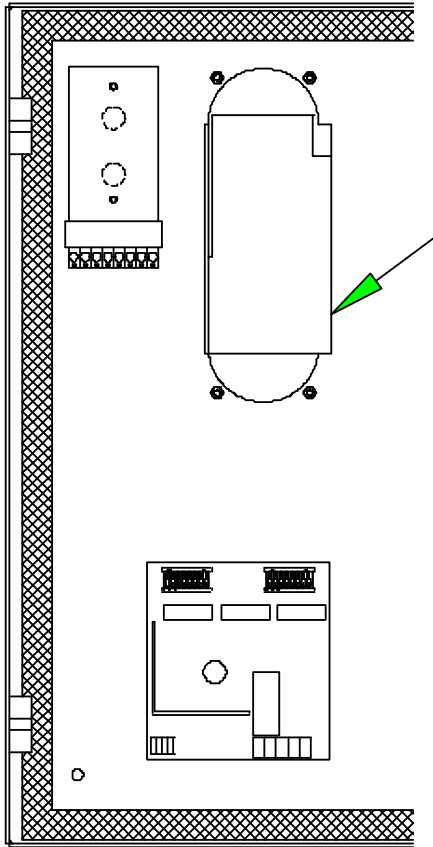
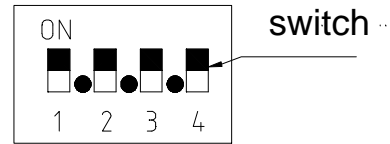

Figure 8: Electronic Coin Control Cashflow 340



Figur 9: Dipomkopplare

The electronic coin control is equipped with a 4-position DIP-switch that used to set prices and to block/allow coins.

#### 3.3.3.1 Change of prices, blocking of coins etc... Cashflow 340.

The following instructions describe how to modify prices, block coins etc.

1. Cut the power supply to the coin control.
2. Dismount the coin control from its holder and remove the interface protection by pulling it downwards. Re-mount the coin control in its holder.
3. Switch on the power supply to the coin control.
4. Adjust the position of the switches according to the respective function.  
If the switches are already in the correct position, then do the following:
  - Change the position of one switch.
  - Switch off the power supply and switch it on again.
  - Re-set the switch in the correct position and press the coin return button.
5. Carry out the desired function.
6. Again cut the power supply to the coin control and re-mount the interface protection.
7. Switch on the power supply.

### Blocking a coin

1. Position the switches 1-4 as shown in the diagram.
2. Press the coin return button once.
3. Insert the coin you wish to block and check that it is blocked.
4. Press the coin return button once.
5. Check that the setting has been carried out.

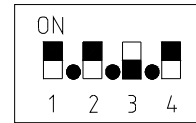

### Allowing a coin

6. Position the switches 1-4 as shown in the diagram.
7. Press the coin return button once.
8. Insert the coin you wish to allow and check that it is accepted.
9. Press the coin return button once.
10. Check that the setting has been carried out.

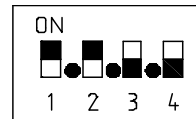

### Changing the price

1. Position the switches 1-4 as shown in the diagram.
2. Press the coin return button once.
3. Insert the coin you wish the price to be and check that it is accepted.
4. Press the coin return button once.
5. Check that the setting has been carried out.

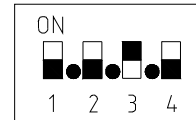

### Test the coin output port

1. Position the switches as shown in the diagram.
2. Press the coin return button.
3. Check that the machine starts dispensing.

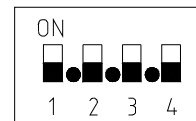

### 3.3.4 Manual magnetic card reader (EMC-30)

This is done by sliding a magnetic card through a card reader. The cards can be programmed to dispense anything between 1 and 30 baskets.

The card reader is equipped with a two digit display showing the number of dispenses left on the card.

You will find the wiring diagram for Magnetic card reader EMC-30 in paragraph 6.3.2.5 "Magnetic car reader EMC-30".

Slide the card downwards through the scanner with the dark magnetic strip held away from you and facing left. The figure which appears in the display shows the number of baskets (including this one!) that you can fill from the machine.

If you only want to know how many baskets you have left, press in the knob on the left of the scanner while sliding the card through. This does not reduce the number of baskets left, as no balls will be dispensed.

Keep the card safe. Do not bend it, and keep it away from strong magnetic fields.

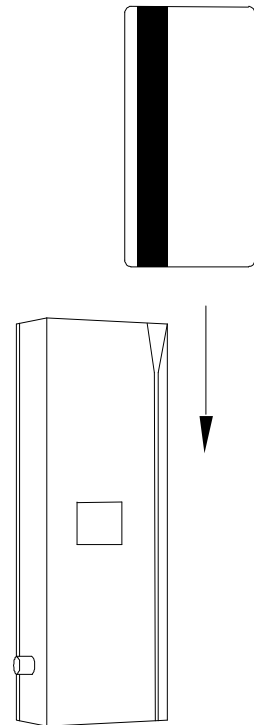

Figure 10: EMC-30

## **4 Design and function**

### **4.1 General**

The machine is intended for use as a golf ball dispenser. It consists of a ball magazine and is inside fitted with two plates on two levels for load reduction and, at the bottom, a grid.

The grid consists of a number of ball ducts, arranged next to each other and ending above a conveyor belt transporting the balls to the ball chute.

A photocell is installed in connection with the conveyor belt counting the balls being transported by the belt.

All interior surfaces are inclined so that the balls are continuously flushed downwards. The lower level allows for damaged balls and debris to be sorted out.

All essential parts of the Ball Dispenser are manufactured of stainless steel, rust protected steel or aluminium.

The Range Servant Boll Dispenser has been designed in order to provide driving range owners with a long-lasting, reliable, practical and economic golf ball management system.

#### 4.1.1 Machine exterior

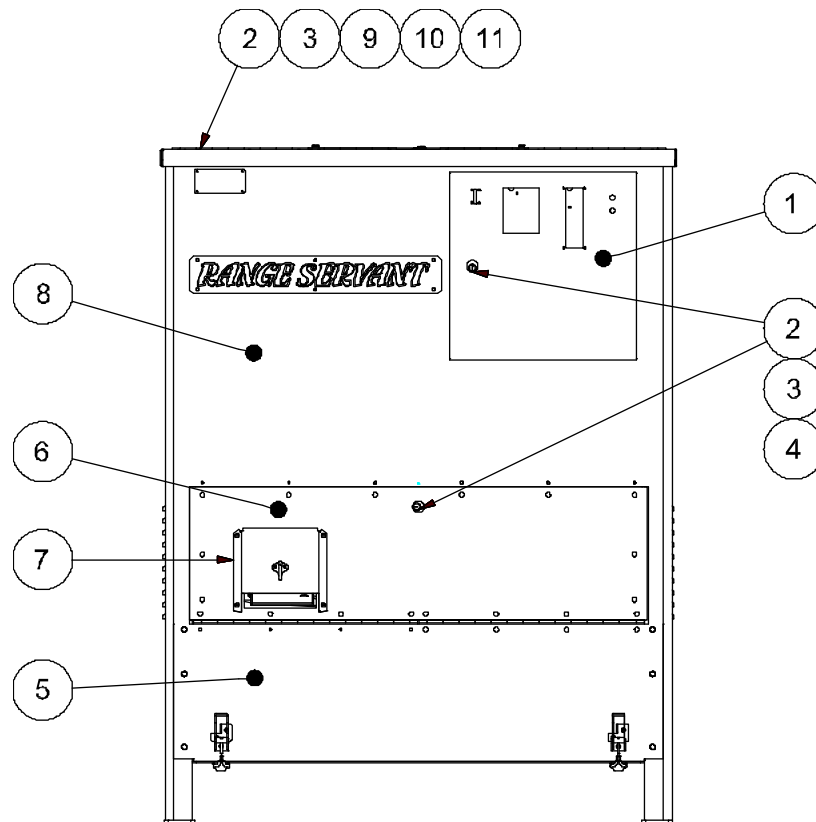

Fig. 11: Outside front view

Pos.	Designation
1	Control box door
2	Locks for control box, front hatch and lid
3	Shackle, front hatch lock and lid
4	Shackle, control box door
5	Lower front panel
6	Front inspection hatch
7	Ball shute
8	Upper front panel
9	Front portion of lid
10	Lid hinges
11	Rear portion of lid

#### 4.1.2 Machine interior

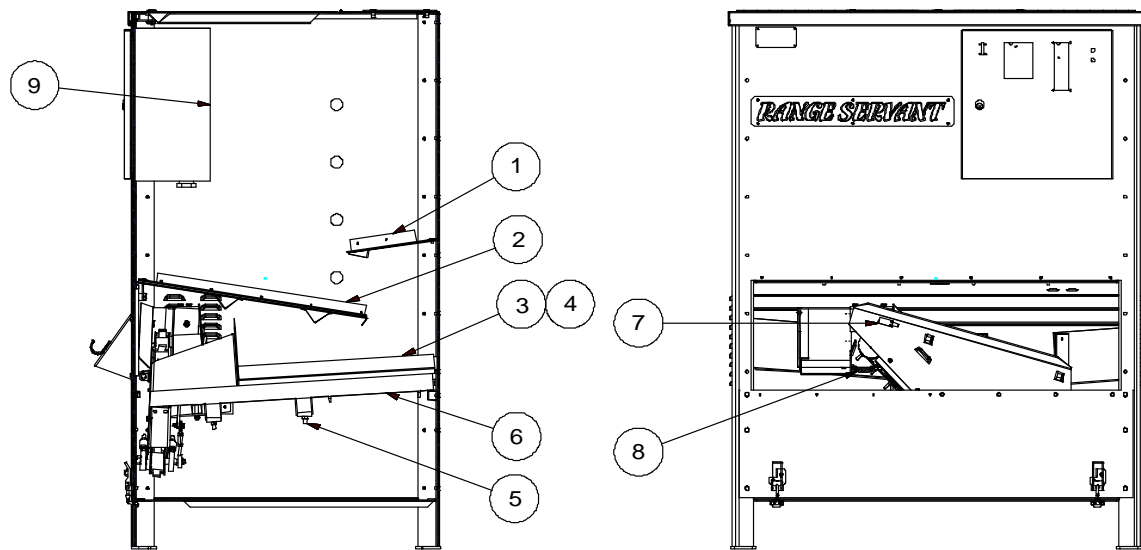

Fig. 12: Inside of the ball dispenser

Pos.	Designation
1	Upper inclined plate
2	Lower inclined plate
3	Left side plate of grid
4	Right side plate of grid
5	Shock absorber
6	Grid
7	Photocell NPN
8	Dispenser motor
9	Control box

## **4.2 Description of components**

### **4.2.1 Grid**

The lowest level inside the ball dispenser consists of a grid. On top of the grid is a movable plate. At one end of the movable plate is a funnel-shaped ball duct discharging onto a conveyor belt divided into compartments. The conveyor belt runs between a lower and upper pulley. The angle of the conveyor belt is designed so that the balls automatically roll on from one compartment to the other until all compartments are filled with balls. An electric conveyor motor runs the upper pulley and thus the conveyor belt. The conveyor motor is connected to an electronic control circuit including a photocell located next to the conveyor belt counting the balls passing on the belt.

### **4.2.2 Payment Methods**

The ball dispenser can be operated with tokens, coins or magnetic cards. Each machine can run more than one payment system at the same time, for example combining token/coin or token/coin/card. The number of balls dispensed need not necessarily be the same for the different forms of payment (see the examples, chapter 3.3.2).

Below you can read how to alter the price on the coin mechanism, both for manual operation and the electronic system.

The price per unit when using a card mechanism is determined by the price of the card and your choice of the number of balls dispensed per card. The cards can be programmed to dispense anything between 1 and 30 baskets. The magnetic cards are programmed by Range Servant®

## 5 Maintenance

### 5.1 General

Range Servant will provide accessories and original spare parts together with competent advice.

Maintenance carried out correctly minimises defects and ensures maximum service life and reliable operation. Any malfunctions are detected at an early stage and are therefore easily corrected. Regular maintenance minimises defects and equipment breakdown. The following maintenance instructions only refer to the most common problems and their causes.

### 5.2 Periodical maintenance

### 5.3 Maintenance intervals and instructions

Maintenance intervals:

1. After 300 operating hours
2. Once every month
3. Once every golf season

Maintenance intervals and instructions		1	2	3
<b>1</b>	<b>Machine exterior</b>			
1.1	Lubricate the eccentric lock, the lid and front hatch locks and the hinges of lid and front hatch with ordinary lubricating oil.		X	
1.2	Lubricate the eccentric lock, the lid and front hatch locks and the hinges of lid and front hatch with ordinary lubricating oil.			X
<b>2</b>	<b>Machine interior:</b>			
2.1	Tighten the fixation bolts of the grid.	X		
2.2	Lubricate the linking arms with ordinary lubricating oil.		X	
2.3	Wipe the photocell that counts the balls. The photocell is located above the conveyor belt. Use a piece of cloth moistened with pure alcohol.			X
2.4	If chemical fertilisers are used on the driving range, we recommend that the dispenser is cleaned thoroughly once a month to prevent corrosion of the machine's internal components. Cut the power supply to the machine, open the front hatch, remove grass and other debris and rinse with clean water.		X	
2.5	Empty the machine, sort out worn or damaged balls, stones and grit etc and clean the inside with normal clean water. (Do not spray water directly onto the electric motor.)			X
2.6	Clean and dry the ball duct (located after the grid).			X
2.7	Clean and dry the conveyor belt.			X



<b>3</b>	<b>Electronic components:</b>			
3.1	If the machine is fitted with a magnetic card reader EMC-30 the reader head has to be cleaned. Moisten a piece of cloth with methylated spirit, wind it round the card and slide the card through the reader 5-10 times.			X

## 5.4 Troubleshooting and repair

Although the operation of the machine is most reliable, problems may arise for various reasons.

### Attention!

To reduce the time spent on troubleshooting, always start by checking that cables and connections are clean and tightened.

SYMPTOMS	POSSIBLE DEFECT	CORRECTIVE MEASURES
The Ball dispenser does not start.	→ The power supply is not connected.	→ Connect the machine to the power supply.
	→ The ON/OFF switch on the circuit card is not "ON"	→ Set the switch in the "ON" position.
	→ Defective fuse(s) on the circuit card.	→ Replace the fuse(s) (2.5A/250V).
	→ Payment method defect.	→ Check the voltage with Ohmmeter. The voltage shall fall from 5VDC to 0VDC when active. All payment methods must be NO (Normally Open).
	→ One payment channel is active..	→ Measure the payment channel voltage and check that no channel is 0VDC.
The Ball Dispenser delivers too many balls.	→ The photocell is not correctly adjusted.	→ Adjust the photocell according to instructions (paragraph 3.2.4 "Adjustment of photocell")
The Ball dispenser delivers too few balls.	→ The conveyor belt speed is not correctly adjusted.	→ Adjust the speed according to instructions (paragraph 3.2.3 "Adjustment of conveyor belt speed").

Fig. 13: Troubleshooting for RS-Ultima 8, 12, 20, 45.

SYMPTOMS	POSSIBLE DEFECT	CORRECTIVE MEASURES
The Ball Dispenser does not start.	<p>→ Token contacts do not close.</p>	<p>→ Check the voltage with Ohmmeter. The voltage should fall from 5VDC to 0VDC when active (=closed position). The token switch must be connected in the NO position (Normally Open).</p> <p>→ Check that the token cable is not damaged or has stuck.</p>
	<p>→ The (Mechanical) Coin Control switch does not close.</p>	<p>→ See above for token switch.</p>
	<p>→ The coin output of Electronic Coin Control Cashflow 340 is not activated.</p>	<p>Activate coin output of Cashflow (acc. to 3.3.3.1 "Change of price, blocking of coins etc."). Measure payment channel with Ohmmeter. Voltage should fall from 5VDC to 0VDC when active. Check the price setting.</p>
	<p>→ The magnetic card reader EMC-30 activity does not appear in the display.</p>	<p>→ There are no dispenses left on the card. Try a new card.</p> <p>→ Check that resistor 33k Ohm is not defective.</p>
	<p>→ EMC-30 purchase indications appear on the display but the displayed number does not change and dispensing does not start.</p>	<p>→ Check that the mechanical switch of the reader unit is not closed.</p>

Figure 14 Troubleshooting for payment methods.

## 5.5 Function test

After maintenance or repair work the operation of the machine should be tested by running the machine with the front hatch open. Insert a coin/token or payment card and check that everything works to satisfaction.

## 6 Installation

### 6.1 Factory testing and configuration

The ball dispensers are always tested and configured before delivery to the customer. On this occasion all the parameters of the control system are adjusted according to the customer's wishes.

Our objective when carrying out this final check is to verify that the product corresponds on all accounts to the requirements laid down by the customer when ordering and to prevent defective products from being brought onto the market.

### 6.2 Installation of the ball dispenser

For trouble free operation, place the ball dispenser on a firm and level surface.

We recommend that the machine be located under cover and that only the front of the machine be accessible to members of the public. If the machine is card-operated, it must stand under cover according to the terms of the warranty.

Remove the keys tied into the opening for the ball shute in the front hatch.

The keys are identical and are used for opening the control box (see arrow).

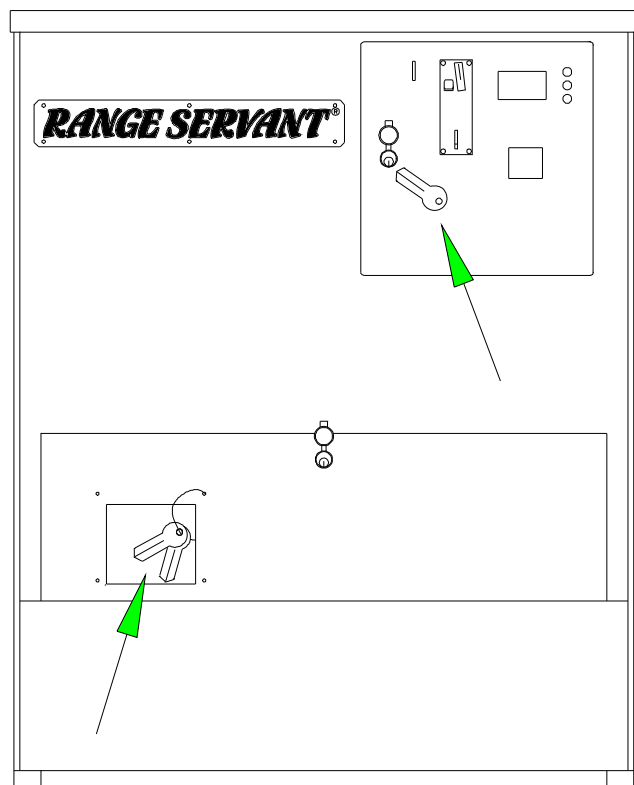

Fig. 15: Location of keys on delivery

Inside the control box there are another four keys, all identical, which fit the lid of the ball dispenser and the front inspection hatch.

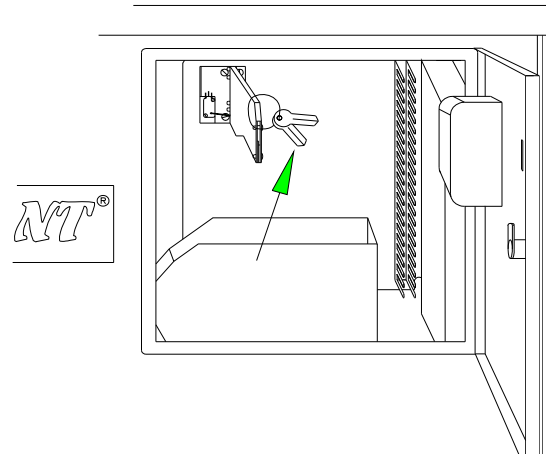

Fig. 16: Location of keys in control box

Open the lid of the ball dispenser and remove the package containing a plastic tray, a ball chute, the number of tokens ordered for the machine and other accessories, if any.

Place the plastic tray inside the control box so that the tokens fall directly into the tray. If the machine is both coin and token operated, there will be two trays for sorting both forms of payment at source.

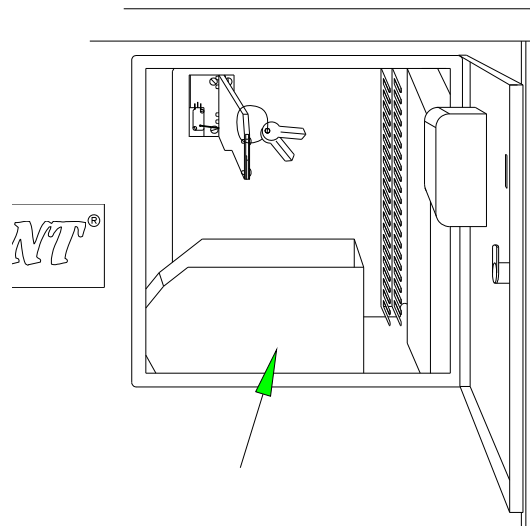

Fig. 17: Location of plastic collecting tray

Screw the ball chute into place over the hole in the front hatch.

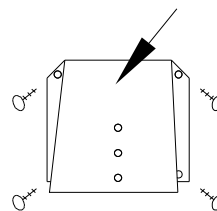
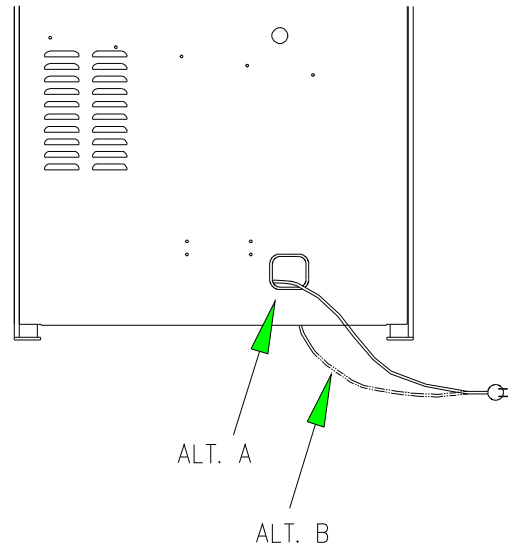

Fig. 18: Mounting of ball chute

The electric cable is located in the bottom of the machine and is pulled out through the hole situated on the side or in the bottom of the machine.

**IMPORTANT!** Do not connect the cable until the machine is ready for operation.



*Fig. 19: Location of the electric cables*

## 6.3 Installation – Wiring Diagram

To ensure safe and reliable operation, the control system must be correctly installed and grounded (earthed) and provided with good immunity against electronic noise.

### 6.3.1 Wiring Diagram for the connection of BA-99 to the Ball Dispenser

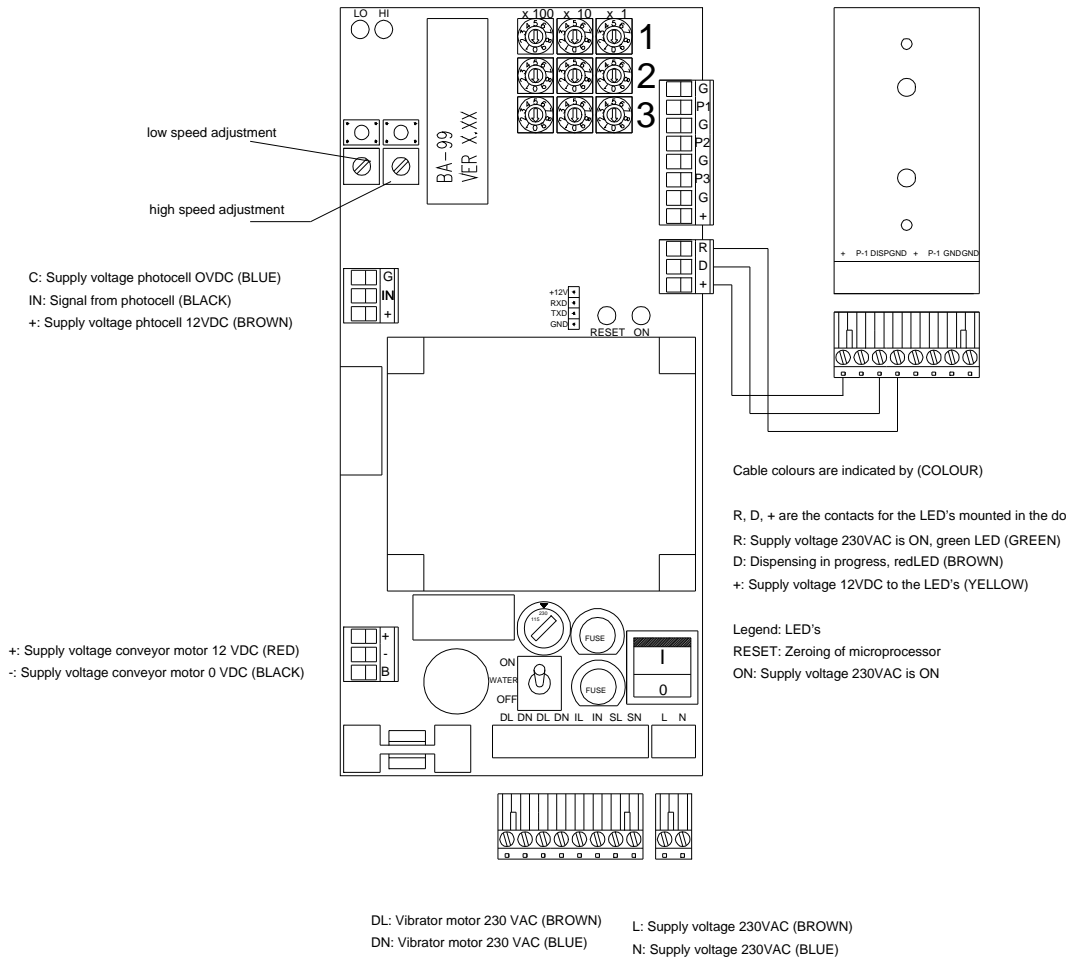

Figure 20: Wiring diagram for the connection of Ball Dispensers model RS-Ultima 8/12/20/45.

## 6.3.2 Wiring of Payment Systems

### 6.3.2.1 Token Control

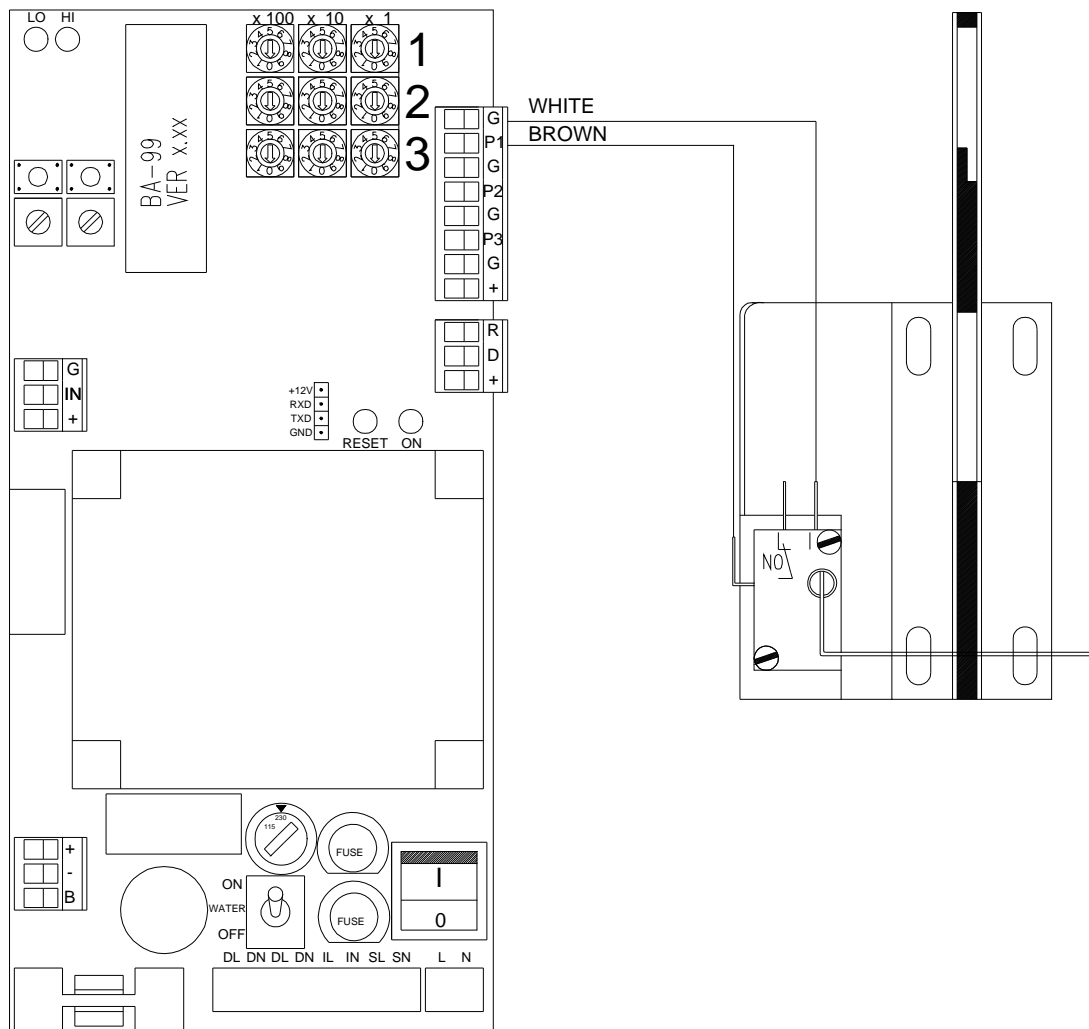

Figure 21:Wiring of Range Servant Token Control.

The token control micro switch is to be installed in the **NO** position - **Normally Open**.



### 6.3.2.2 Mechanical Coin Control

The mechanical coin control is wired according to the same wiring diagram as the token control (see above “Token”)

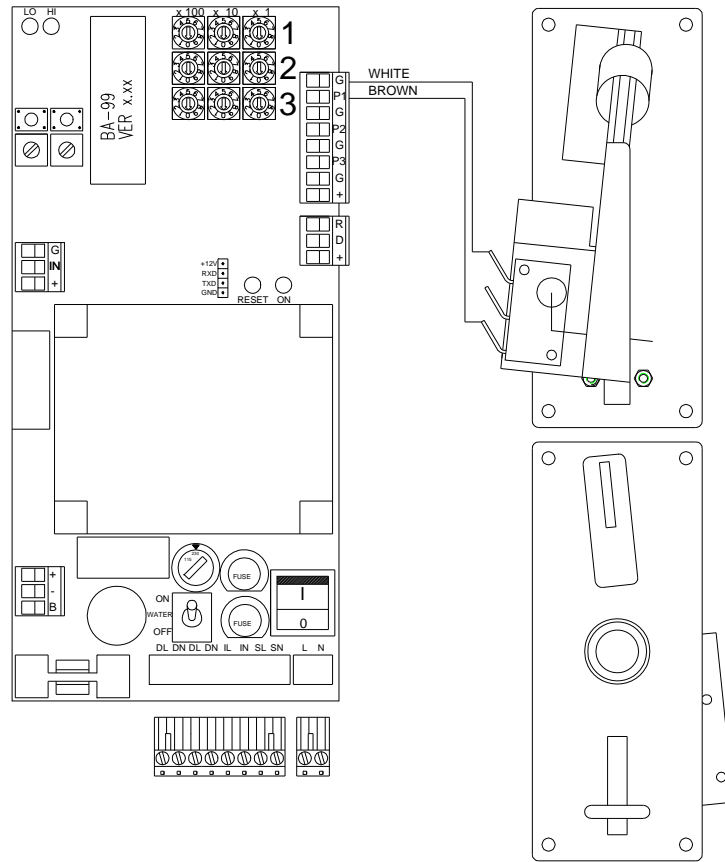

Figure 22 Wiring of the one coin mechanical coin control

### 6.3.2.3 Mechanical Coin Control with “adding” printed circuit card

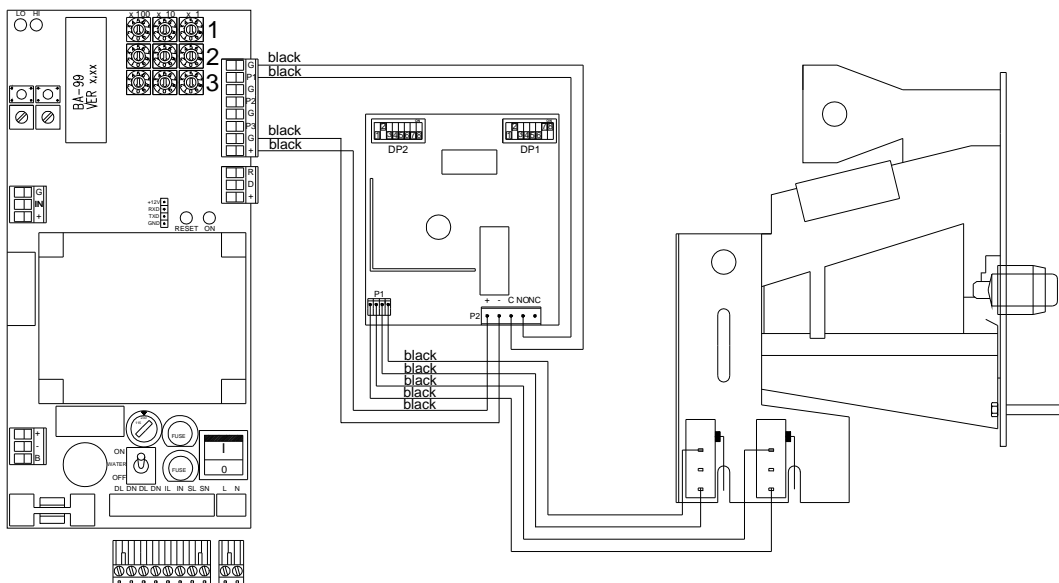

Figure 23 Wiring of 2-coin+adding printed circuit card.

### 6.3.2.4 Electronic Coin Control (Mars® Cashflow 340)

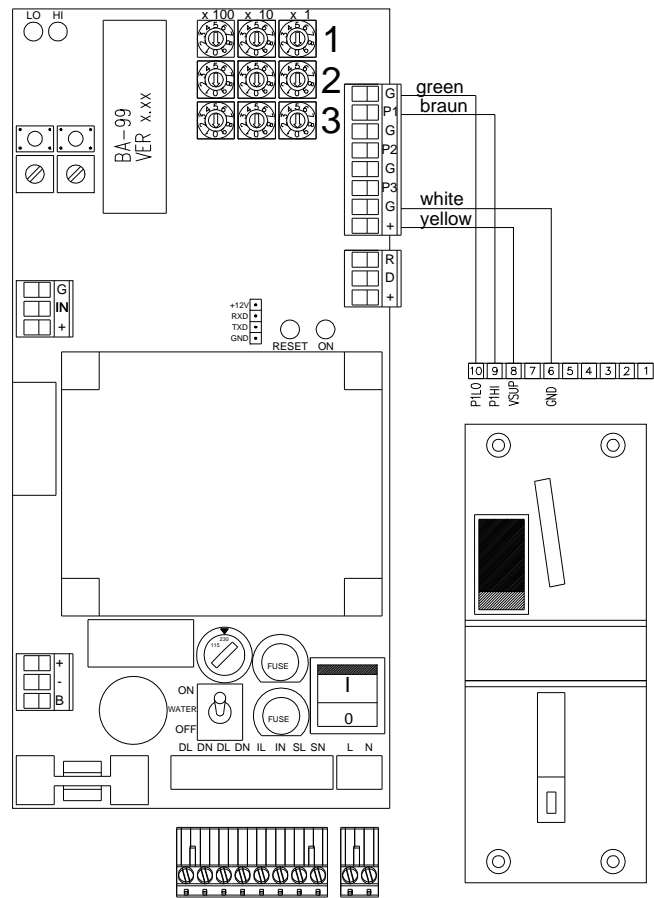

Figure 24: Wiring of the Coin Control Mars® Cashflow 340.

The electronic coin monitor Cashflow 340 is a totaliser, programmed to send a signal causing the ball dispenser control system to start dispensing when the internal pre-set price has been reached. Twelve different types of coins/tokens can be programmed.

### 6.3.2.5 Magnetic Card Reader EMC-30

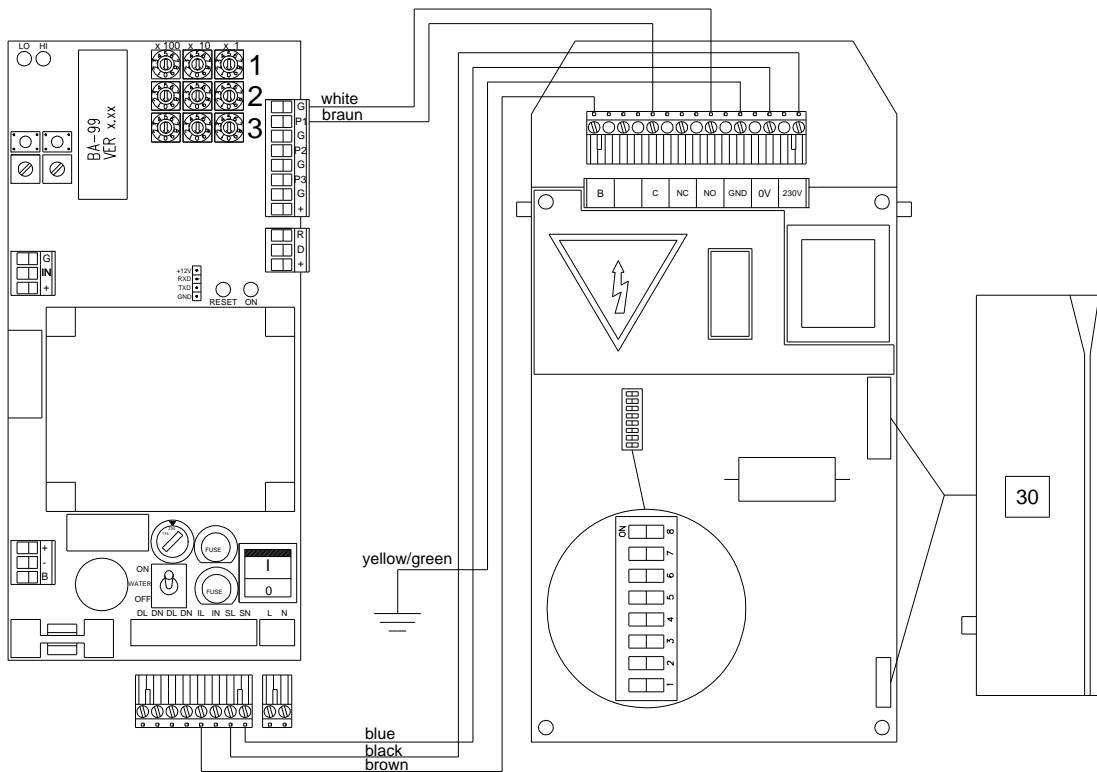

Figure 25: Wiring of the card reader EMC-30.

The Card Reader uses pre-programmed magnetic cards that can be programmed for up to 30 purchases.  
The magnetic cards will be programmed by Range Servant.

### 6.3.2.5 Counter

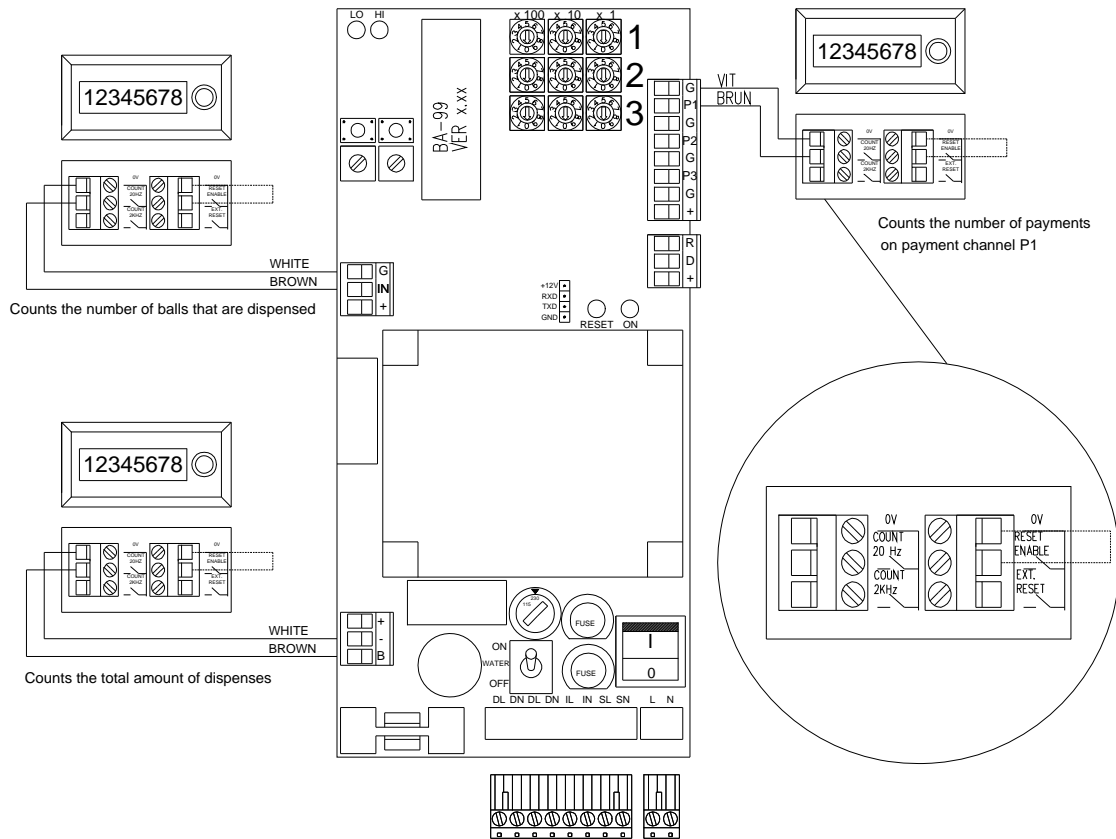

Figure 26 Wiring of counter.

### 6.3.3 Cables

ATTENTION! No cables may be exchanged without the prior consent of Range Servant.

#### 6.3.3.1 Cable Specifications

Unit	Cable Type
Mains supply	RKK 3x0.75mm <sup>2</sup>
Motor (Dispenser)	RKK 2x1mm <sup>2</sup>
Photocell	LIYY 4x0.22mm <sup>2</sup>

#### 6.3.3.2 Power supply

All machines can be supplied with 230/115 VAC +/- 10% 50-60Hz.

## 7 Spare parts

In this chapter you will find detailed drawings of the ball dispenser showing the location of the different spare parts. The tables accompanying the drawings contain information about spare parts number and designation and the quantity of each spare part installed per machine model.

( )= Optional accessories are marked with a parenthesis around the digit representing quantity.

- = The alternative marked with "-" depends on the customer's choice of equipment.

### 7.1 External

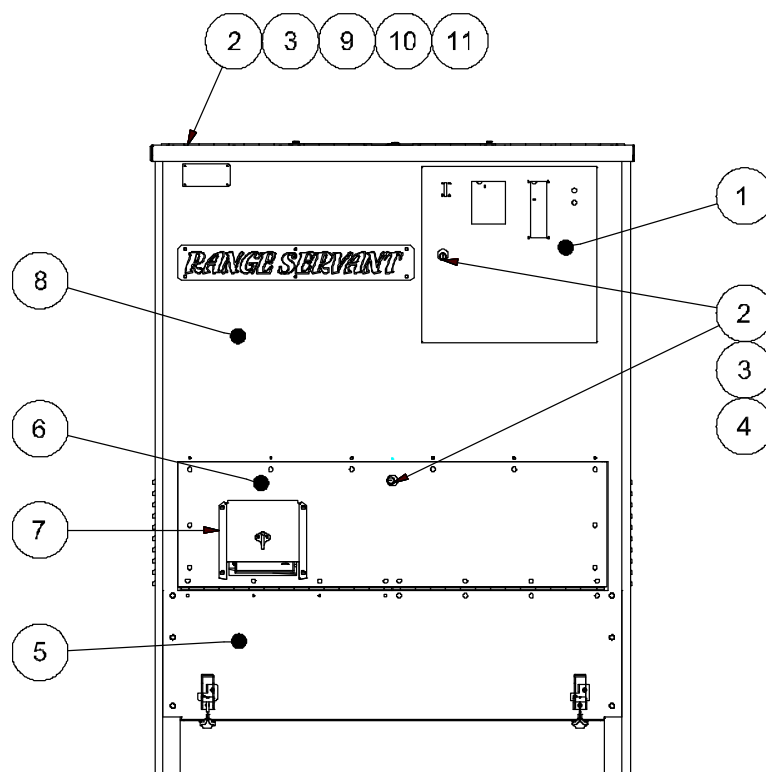

Fig. 27: Front view

Pos.	Part No.	Designation	Ultima-8	Ultima-12	Ultima-20	Ultima-45
1	-	Control box door	1	1	2	2
2	101900	Lock for control box, front inspection hatch and lid	1	1	2	2
3	101950	Shackle, front hatch lock and lid	1	1	2	2
4	101960	Shackle, control box door	1	1	2	2
5	DJM 1505	Lower front panel	1	1	2	2
6	DJM 1506	Front inspection hatch	1	1	2	2
7	102000	Ball shute	1	1	2	2
8	DJM 1504	Upper front panel	1	1	2	2
9	106610	Front portion of lid	1	1	1	1
10	106550	Lid hinges	1	1	2	2
11	106500	Rear portion of lid	1	1	-	-

## 7.2 Control box

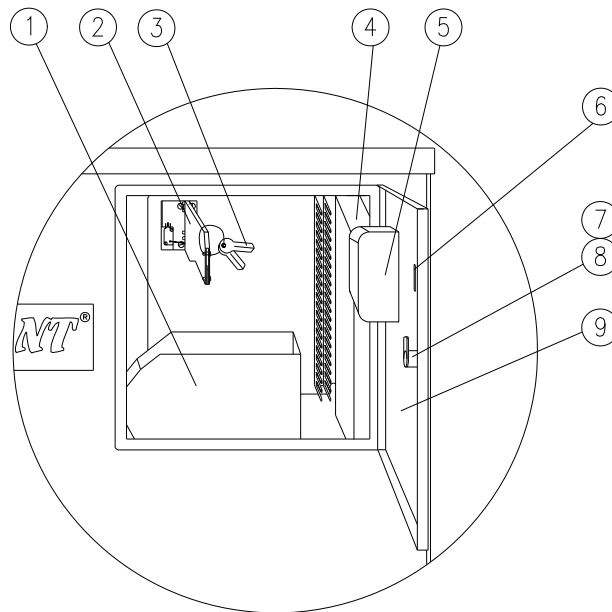

Fig. 28: Control box

Pos.	Part. No.	Designation	Ultima-8/12	Ultima-20/45*
1	109410	Token collecting tray, small	1	1
1	109400	Token collecting tray, large	(1)	(1)
2	108600	Token monitor	1	1
3	101920	Spare keys	-	-
4	930125	Printed circuit board BA-99	1	1
5	-	Coin monitor	-	-
6	-	Token slot	-	-
7	101900	Lock	1	1
8	101960	Shackle, control box door	1	1
9	-	Control box door	1	1

( ) Optional equipment is within brackets

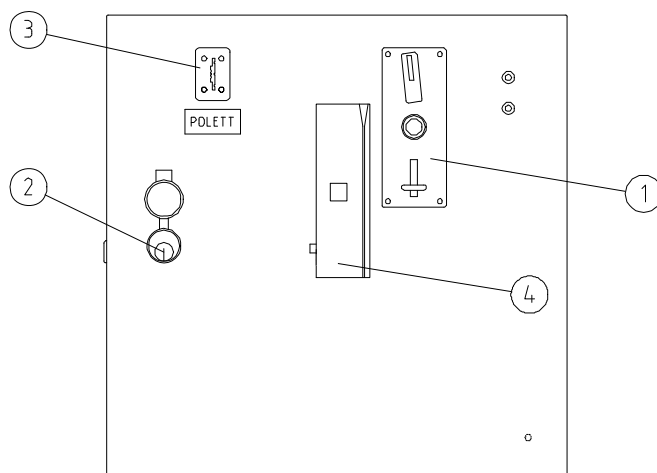

Fig. 29: Control box, token, magnetic card reader and mechanical coin control

### 7.2.1 Control box door with mechanical coin control

Pos.	Part No.	Designation	Ultima-8/12	Ultima-20/45*
1	OKA0000	Mechanical coin control	(1)	(1)
2	101900	Lock	1	1
3	-	Token slot for the type of token used	1	1
4	108000	Magnetic card reader EMC-30	(1)	(1)

( ) Optional equipment is within brackets  
 \* quantity per side

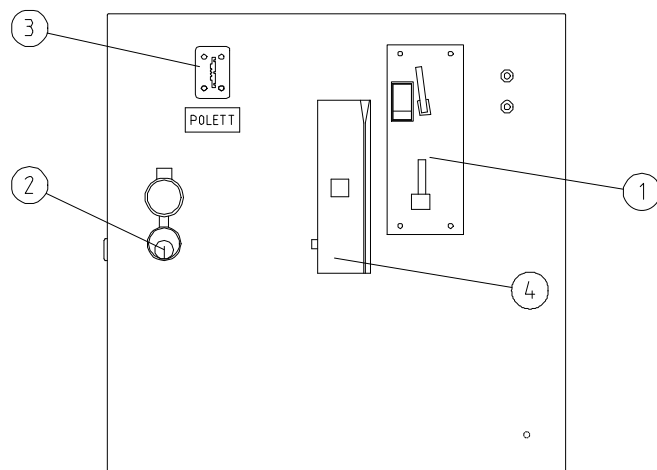

Figure 30: Control box, token, magnetic card reader and electronic coin control

### 7.2.2 Control box door with electronic coin control

Pos.	Part No.	Designation	Ultima-8/12	Ultima-20/45*
1	107900	Electronic coin control	(1)	(1)
2	101900	Lock	1	1
3	-	Token slot for the type of token used	1	1
4	108000	Magnetic card reader EMC-30	(1)	(1)

( ) Optional equipment is within brackets  
 \* refers to quantity per side

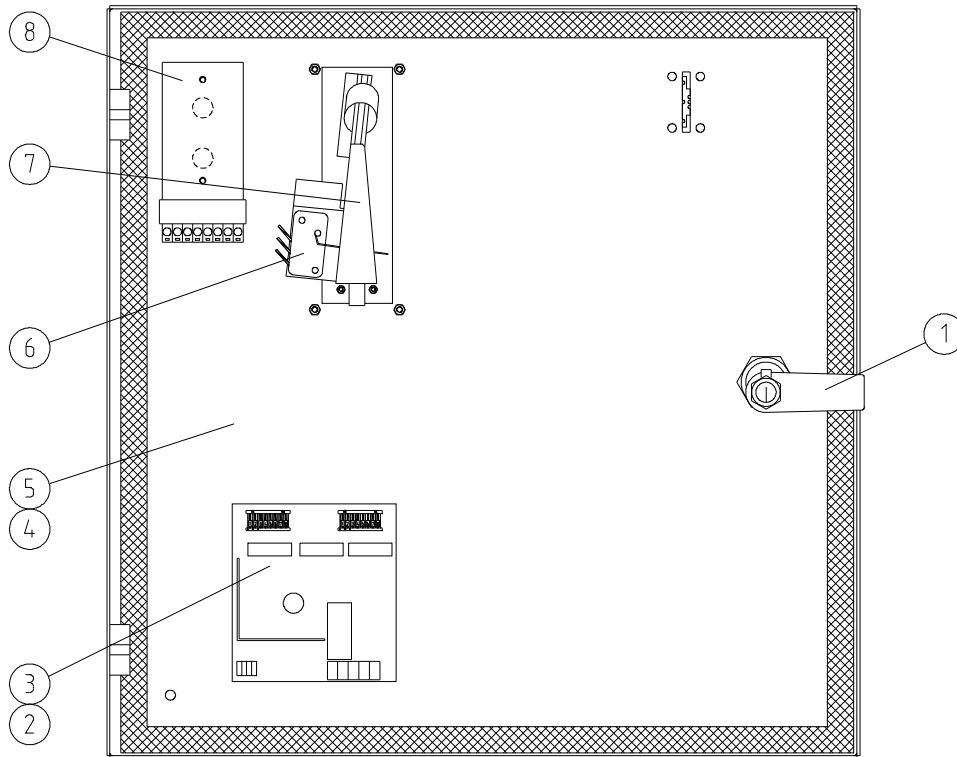

Figure 31: Inner side of the control box door with mechanical coin control

### 7.2.3 Inner side of the control box door with mechanical coin control

Pos.	Part no.	Designation	Ultima-8/12	Ultima-20/45*
1	10 1900	Complete lock	(1)	(1)
2	10 7800	Circuit card 1/5, 2 coin mechanism	(1)	(1)
3	10 7810	Circuit card 1/2, 2 coin mechanism	(1)	(1)
4	10 7310	Opening for token and 1 coin	(1)	(1)
5	10 7320	Opening for token and 2 coin	(1)	(1)
6	10 7720	Micro switches	(1)	(1)
7	10 7700	Coin control, 1 coin	(1)	(1)
7	10 7710	Coin control, 2 coin	(1)	(1)
8	930295	Circuit card with LED -99	1	1

() Optional equipment is within brackets

\* refers to quantity per side



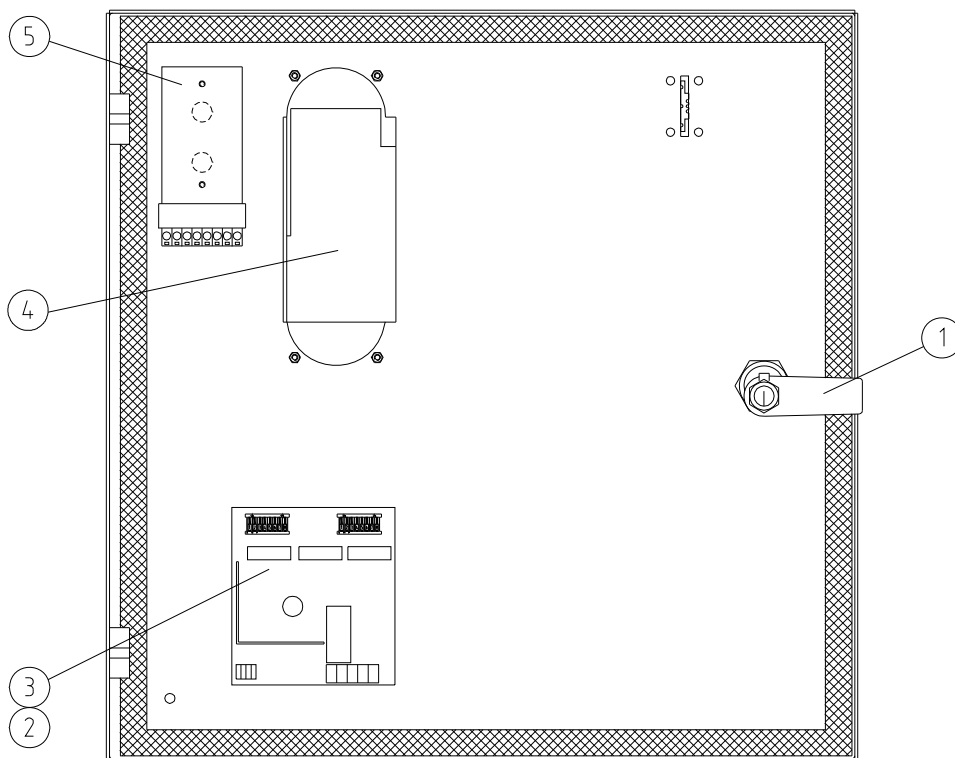

Figure 32: Inner side of the control box door with electronic coin control

#### 7.2.4 Inner side of the control box door with electronic coin control

Pos.	Part no.	Designation	Ultima-8/12	Ultima-20/45*
1	10 1900	Complete lock	1	1
2	10 7800	Circuit card 1/5, 2 coin mechanism	(1)	(1)
3	10 7810	Circuit card 1/2, 2 coin mechanism	(1)	(1)
4	107901	Electronic coin control, Cashflow 340	(1)	(1)
5	930295	Circuit card with LED's, LED-99	1	1

() Optional equipment is within brackets

\* refers to quantity per side

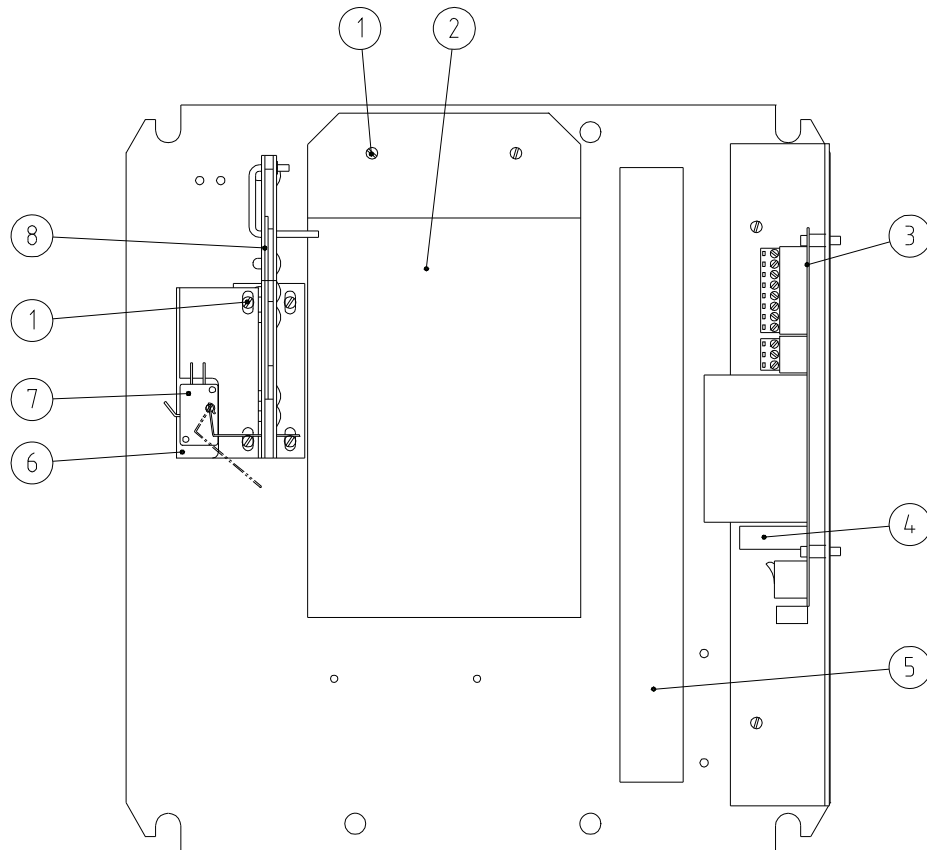

Figure 33: Inside of control box, EMC-30 card reader

### 7.2.5 Inside the control box, EMC-30 card reader

Pos.	Part no.	Designation	Ultima-8/12	Ultima-20/45*
1	01 5020	Screws	(2)	(2)
2	10 8000	Card reader	(1)	(1)
3	93 0235	Circuit card BA-99	(1)	(1)
4	10 9310	Fuse (2,5A250V)	(2)	(2)
5	10 9500	Cable duct	(1)	(1)
6	10 8880	Micro switch holder	(1)	(1)
7	10 8900	Complete micro switch	(1)	(1)
8	10 8600	Token mechanism	(1)	(1)

( ) Optional equipment is within brackets

\* refers to quantity per side

### 7.3 Internal

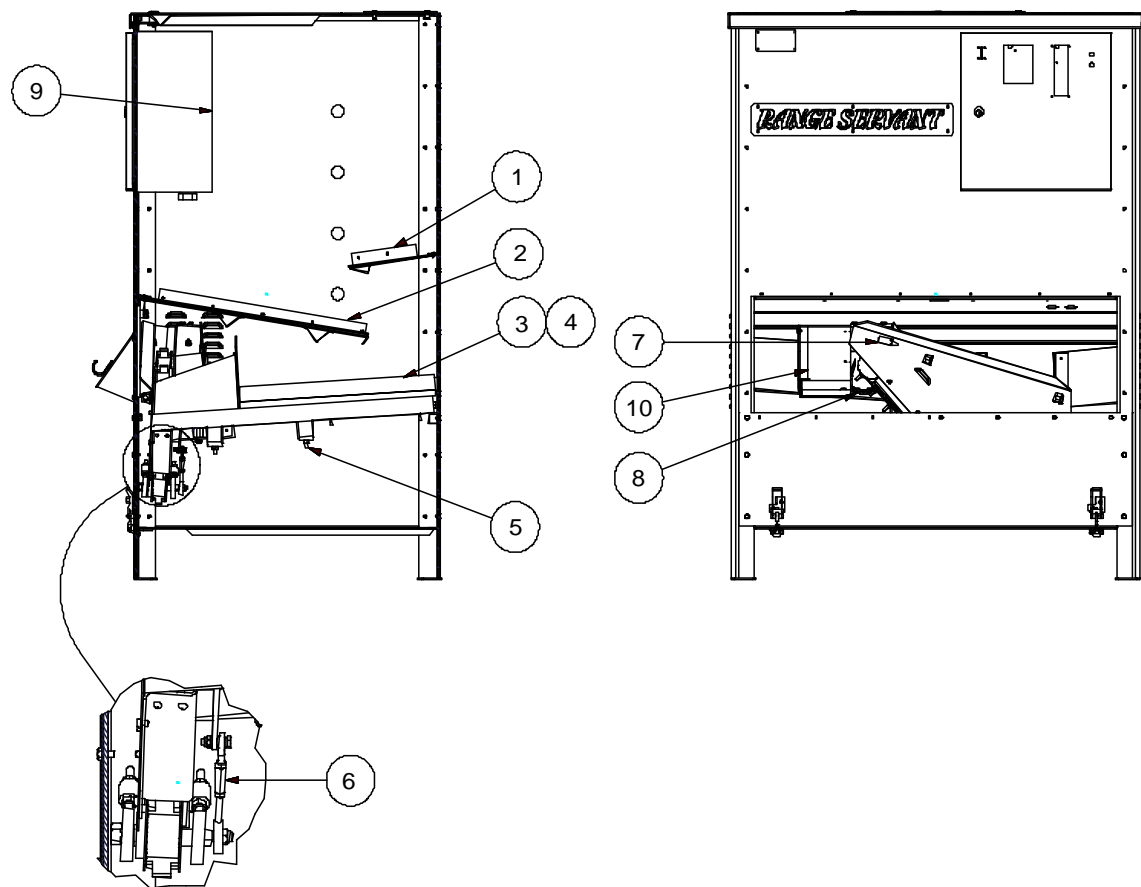

Figure 34: Cross section

Pos.	Part no.	Designation	Ultima-8	Ultima-12	Ultima-20	Ultima-45
1	182600	Upper inclined plate	1	1	2	2
2	182700	Lower inclined plate	1	1	2	2
3	DJM0033	Left side plate of grid	1	1	2	2
4	DJM0034	Right side plate of grid	1	1	2	2
5	DJA0004	Shock absorber	1	1	2	2
6	DJM0057	Linking arm	1	1	2	2
7	930218	Photocell, counter	1	1	2	2
8	DJA0003	Motor	1	1	2	2
9	-	Control box	1	1	2	2
10	DJM0080	Ball chute	1	1	2	2

### 7.3.1 Grid

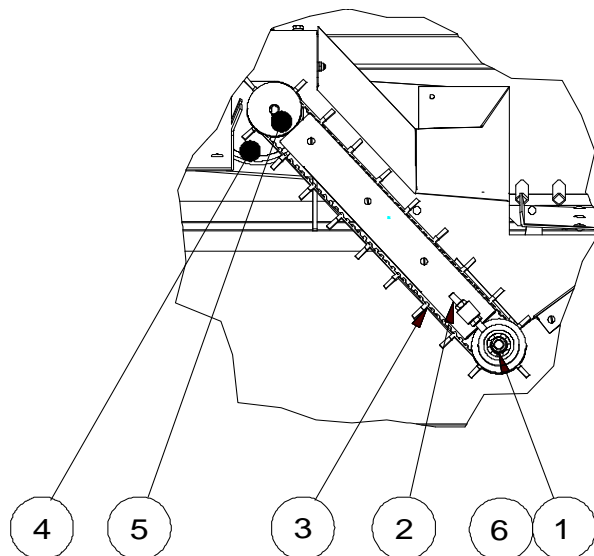

Figure 35: View of the grid through the open front hatch

Pos.	Part no.	Designation	Ultima-8	Ultima-12	Ultima-20	Ultima-45
1	DJM0054	Axle for conveyor belt pulley	1	1	2	2
2	DJM0055	Clamp screw	2	2	4	4
3	DJA0006	Conveyor belt	1	1	2	2
4	DJA0003	Conveyor motor	1	1	2	2
5	DJM0048	Conveyor belt pulley	1	1	2	2
6	DJM0029	Conveyor belt pulley	1	1	2	2

## 8 Retailers and representatives

The following list contains all the necessary information concerning the Range Servant representative closest to where you live.

The list is continuously updated on our home page <http://www.rangeservant.com>

### 8.1 Head Office

#### Sweden

##### Range Servant AB

Skallebackavägen 11

302 41 HALMSTAD

Telephone: +46 35 10 92 40

Fax: +46 35 10 82 20

E-Mail: [sales@rangeservant.com](mailto:sales@rangeservant.com)

### 8.2 Your Sales Representative







**MADE IN  
SWEDEN**

since 1986

Founded in Halmstad, Sweden in 1986, Range Servant's founder, Jordan Knez, saw a need to improve equipment for the golf industry. Using sustainability and durability as guiding principles, he combined his enthusiasm for golf and technical expertise to develop Sweden's first ball dispensers, washers, and ball pickers. In the early 90's, Range Servant expanded to the United States and developed a distributor network around the world. In 2023 we finally expanded into the UK with our own company. Range Servant handles nearly 10 billion balls annually and are considered the market leader in driving range equipment.

Range Servant produces and sells driving range equipment and solutions that manage the picking, washing, dispensing, and overall handling of golf balls. Each customer is unique, and we are always happy to assist with technical support, spare parts, installation, and project management. Range Servant offers a wide variety of accessories to round out a complete catalog of high-quality range equipment.

**Our goal is to inspire the golfer to hit more balls  
and to help the range owner operate a carefree  
and more profitable business.**

***RANGE SERVANT***<sup>®</sup>

**RANGE SERVANT AB** | Skallebackavägen 11 | SE-302 41 Halmstad | Sweden  
Phone: +46 35 10 92 40 | [support@rangeservant.com](mailto:support@rangeservant.com) | [www.rangeservant.com](http://www.rangeservant.com)

