



ENGLISH

RANGE SERVANT[®]

<http://www.rangeservant.com>

USER'S MANUAL

ELEVATOR



- RS-1.8
- RS-2.3
- ULTIMA-1.4
- ULTIMA-2.1
- DITCH ELEVATOR
- MULTI-STOREY ELEVATOR

TABLE OF CONTENTS

1	<u>General Information</u>	4
1.1	Preface	4
1.2	Manufacturer's Declaration	5
1.3	Description	6
1.3.1	Elevator	6
1.3.2	Ball Management System	6
1.4	Identification	6
1.5	Technical Specifications	7
2	<u>Safety</u>	9
2.1	General	9
2.2	Conformity with mandatory requirements	9
2.3	Remaining risks	9
2.4	Authorised use	10
2.5	Not authorised use	10
2.6	Emergencies	10
2.6.1	Fire	10
2.7	Operational reliability	10
3	<u>Operation</u>	11
3.1	Necessary qualifications	11
3.2	Operating the Elevator	11
3.2.1	Start and stop	11
4	<u>Design and function</u>	12
4.1	General	12
4.1.1	Main components	12
5	<u>Maintenance</u>	13
5.1	General	13
5.2	Periodical maintenance	13
5.2.1	Monthly	13
5.2.2	Once every season	13
5.3	Fault analysis and repair	14
5.3.1	General	14
5.3.2	Fault analysis	14
6	<u>Installation</u>	15

6.1	Unpacking and assembly	15
6.2	Assembly of the elevator for BTW Dispenser	16
7	Spare parts	17
7.1	Spare parts number	17
7.1.1	Elevator for machines with a flat top: RS-1.8/Ultima-1.4	17
7.1.2	Elevator for machines with a conic top: RS-2.3/Ultima-2.1	18
7.1.3	Elevator for BTW dispensers: BTW Ultima 9-30	19
7.1.4	Ditch-Elevator	20
7.1.5	Multi-storey Elevator	21
8	Retailers and representatives	23
8.1	Head Office	23
8.2	Your Sales Representative	23

Title:	Br02elevator-E.doc
Prepared by:	Johan Carlsson
Date:	19/02/2007
Antal ord:	3340
Version:	45

1 General Information

1.1 Preface

We congratulate you to your new Range Servant machine. You have made a good choice! Not only have you chosen an excellent state-of-the-art Elevator with little demands on maintenance but you have also chosen quality. Quality is ensured with the help of modern production techniques, carefully chosen materials and the responsible workmanship of our staff.

The purpose of the User's Manual is to acquaint the user with this type of machine so that he is familiar with its use in different situations and for different types of work! This Manual includes all the drawings and diagrams necessary for putting the machine into operation and for carrying out maintenance, inspections, functions tests and repairs as well as other useful information particularly in regard of safety.

Study the User's Guide carefully before using the machine. If these instructions are not followed, persons using the machine might be injured or the equipment itself be damaged. In many cases, following the instructions is a necessary condition for Range Servants' warranty to be applicable. Every person operating the machine must read these instructions.

No part of this publication may be reproduced without the written authorisation of Range Servant.

The Elevator has a one-year warranty. Study the warranty conditions carefully and keep them in a safe place. If you have any questions, or if problems should arise, please contact your Range Servant representative.

ONE YEAR WARRANTY

Range Servant AB hereby offers a warranty of one year from the date of shipment from the factory on material and function of the RANGE SERVANT product specified in this Manual. This engagement applies to repaired or replaced components for a period of three months. This undertaking only applies to the original purchaser. Furthermore, it is limited to the components that the manufacturer finds to be faulty when inspected. Repairs or replacement of components shall be carried out by a representative authorised by the manufacturer. The manufacturer further guarantees that the equipment supplied corresponds to the product description issued. **THE UNDERTAKINGS SPECIFIED IN THIS AGREEMENT CONSTITUTE THE MANUFACTURER'S SOLE OBLIGATION TOWARDS THE PURCHASER. THE MANUFACTURER DECLINES ALL RESPONSIBILITY FOR ANY FORM OF PROMISE OUTSIDE THE FRAMEWORK OF THIS GUARANTEE CERTIFICATE.** The manufacturer also declines all responsibility for promises that might have been made by a third party in conjunction with the sale. The guarantee contract does not apply to equipment that has been repaired nor has had components replaced by persons/companies not authorised by the manufacturer. The manufacturer's guarantee is void if equipment has been incorrectly used, damaged by lack of maintenance / accident or has not been handled in accordance with the written user's manual supplied on delivery. Finally, the manufacturer is exempted from financial responsibility for any kind of injury which might arise in conjunction with the sale and repair of equipment, and from injury suffered by third parties in conjunction with use of the product.

1.2 Manufacturer's Declaration

According to directive 89/392/EEC, article 4.2 and annex 2B

The Manufacturer:

RANGE SERVANT[®]

Range Servant AB
Skallebackavägen 11
SE- 302 41 HALMSTAD
Sweden

The Representative:

(To be filled out by a representative established within the EU)

.....
Company

.....
Address

.....
Telephone

hereby declares:

.....
Machine

.....
Type

.....
Serial no., manufacturing no. etc

- Is intended to be installed in a bigger machine or be combined with another machine, together with which it will constitute a machine covered by Council Directive 89/392/EEC, including its annexes;
 - therefore does not conform in every respect with conditions laid down in the Directive;
- and
- that the harmonised standards 292-1, 292-2 and 292-2A (or parts thereof) have been applied;
 - that the following national standards and technical specifications (or parts thereof) have been applied;

.....
(only if applicable)

and furthermore declares that the machine may not be put into service until the machine in which it will be installed or of which it will be a part is in conformity with, and has been declared to be in conformity with, Council Directive 89/392/EEC and the corresponding national legislation, i.e. in its entirety including the machine concerned by this Declaration.

Halmstad,

.....
Date

Elvis Knez
President

.....
Signature

1.3 Description

1.3.1 Elevator

Available in several standard lengths, the RS-Elevator is a workhorse. Activated with the push of a button, it eliminates the heavy lifting connected with work on today's ranges. Its design is simple; the number of moving parts has been reduced to a minimum. As there are no failure prone bearings or tight couplings, hardly any maintenance is required. Transporting 30 000 golf balls every hour of every day, the RS-Elevator can be seen at the busiest ranges all over the world. The elevator can be automated and designed according to the customer's wish to fill one or multiple ball dispensers.

1.3.2 Ball Management System

Range Servant can deliver a complete, flexible Ball Management System adaptable to any kind of driving range requirements. The Ball Dispenser can be combined with the work-efficient, environment friendly Ball Washer. The Ball Washer in turn can be connected to the Elevator, the Conveyor Belt or the Blower for the transport of clean, undamaged balls from Washer to Dispenser. The system also includes a Ball Picker; a machine picking up used balls from all over the driving range. Thus the circle is closed and manual work has been reduced to a minimum.

By applying our extensive know-how to the specific problems of every driving range we are able to offer tailor-made solutions.

1.4 Identification

When contacting Range Servant, please identify your machine with the help of the information contained in the identification plate. The identification plate is well visible and firmly attached and contains the following information:

- Name and address of the manufacturer
- CE-marking
- Designation of series or type of machine
- Serial no., if any
- Year of manufacture

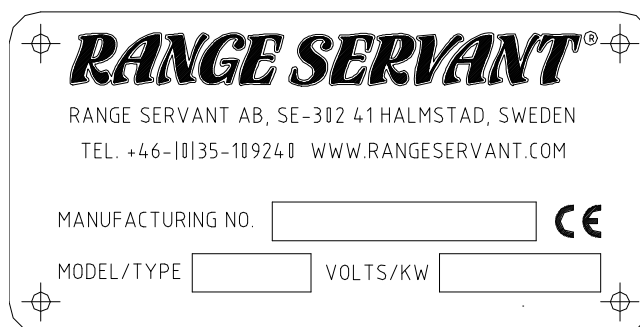

Fig. 1: Product identification plate

1.5 Technical Specifications

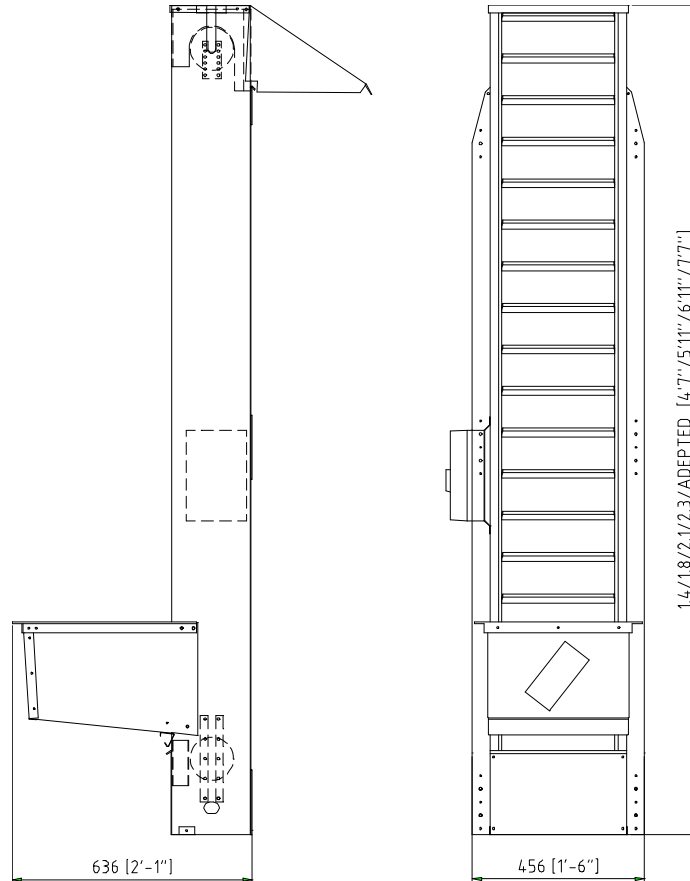

Figure 2: Main measurements

General	
Lifting capacity [balls/min]	500
Measurements:	
Depth [mm] /([in])	636 (25)
Width [mm] /([in])	456 (17.9)
Height [m] /([in]) (height may be adapted to requirements)	1.4/2.1, 1.8/2.3 (55.1/82.7, 70.7/90.6)
Weight [kg]	27/42, 35/46
Electric system:	
Voltage [V, 50 Hz]	230
Motor effect [kW]	0.11
Optional equipment:	
Adjustable speed	
Operating Conditions:	
Operating Temperature [°C] /([°F])	- 10 - + 50 (+14- +122)

The level of airborne noise has been measured for an identical machine under normal operating conditions.
The values indicate the sound pressure level measured 1 m from the surface of the machine and 1,6 m from the floor or access platform.

Sound Pressure				
Sound pressure at the machine (dB, Lin)	XX	XX	XX	XX
Sound pressure at the machine (dB, A)	XX	XX	XX	XX

*The manufacturer reserves the right to make alterations without prior notice.
Patents and patent applications: SE 9300299-6, US 5441145*

2 Safety

2.1 General

Safety measures are a combination of measures taken by the manufacturer when designing and building the machine and measures that have to be taken by the user. The machine has been designed to function for its intended purpose. It has been designed and manufactured so that configuration and maintenance work can take place with the least possible risks to the operator, provided such work is carried out according to the instructions laid down in the User's Manual. The objective of the safety measures is to eliminate all accident risks during the operational life of the machine which also includes the assembly and dismantling of the machine, including any hazards arising as a consequence of such abnormal circumstances as can be anticipated.

Accessories and spare parts that have not been approved by Range Servant can lead to personal injuries and/or equipment damage and affect the operational reliability of the machine. For the sake of safety you should therefore exclusively use accessories and original Range Servant spare parts recommended by Range Servant. Such accessories and spare parts are specially intended for the machine and are approved by us with regard to safety.

All Range Servant retailers keep accessories and spare parts at your disposal and are happy to give you competent advice. They also have the technical qualifications necessary for installing your machine and are informed about what technical changes are authorised.

Damage caused by the use of accessories and spare parts not having been approved by Range Servant as well as damage due to un-authorised technical alterations are not covered by the guarantee.

2.2 Conformity with mandatory requirements

The Range Servant ball management machines fulfil the personal safety requirements of the EU Machine Directive 89/392/EEC as amended by Directives 91/368/EEC, 93/44/EEC and 93/68/EEC, with a special reference to Annex I of the Directive concerning essential health and safety requirements in connection with the design and manufacture of machines, as amended by Directive 91/368/EEC. Furthermore the harmonised standards 292-1, 292-2 and 292-2A (or parts thereof) have been applied. The electrical equipment fulfils the safety provisions laid down in the EU low voltage directive 73/23/EEC, as amended by directive 93/68/EEC.

2.3 Remaining risks

There are warning signs serving as a reminder and warning to the user of any remaining risks, i.e. risks that we have not been able to eliminate, or sufficiently minimise, in our design and against which technical safety measures do not provide complete, or sufficient, protection. The warning signs shall be written in the local language and, upon request, in the language understood by the respective operator. The signs are yellow with black characters. They are big enough to be readable from a distance of three meters.



Fig. 3: Warning sign on front hatch

- Always disconnect the power supply to the machine before carrying out maintenance or service work. The mains switch is located in the lower right hand corner of the printed circuit board.
- Mechanical or electrical alterations may only be undertaken after consultation with Range Servant.

2.4 Authorised use

The elevator may only be used in combination with other Range Servant machines. It may only be used to transport golf balls vertically, between different levels. For the machine to operate satisfactorily, the balls must be clean and undamaged

2.5 Not authorised use

Using accessories or spare parts not recommended by Range Servant might cause personal injury and/or equipment damage and affect the operational reliability of your machine. For safety reasons, only use components recommended by us. They are intended for your machine, they have been chosen for safety reasons and they are approved by the manufacturer.

Damage caused by the use of accessories and spare parts that are not approved by Range Servant, or damage due to un-authorised technical alterations are not covered by the guarantee.

2.6 Emergencies

2.6.1 Fire

Water shall be used as an extinguisher in the event of fire, except if the fire is located in the electric equipment, where a carbon dioxide extinguisher must be used.

2.7 Operational reliability

For trouble-free operation and long service life the instructions below should be followed:

- Check that the conveyor belt moves straightly. If not, the load is unevenly balanced which might affect the service life of the belt
- Make sure that the machines are installed vertically and are placed on a firm and level surface.
- The ditch elevator shall be bolted to the short end of the ditch.

3 Operation

3.1 Necessary qualifications

The technical design and function of the machine is such that the person carrying out service and maintenance work must have the necessary qualifications. He shall have attended a documented training course consisting of the study of the User's Manual, at the end of which he must have well understood its contents.

If the person is absent from work for more than three months, training must be renewed.

3.2 Operating the Elevator

3.2.1 Start and stop

Elevator models equipped with an electric enclosure are started by pushing the green button on the enclosure and stopped by pushing the red button. See Figure 4:

The other models are started by means of the on-off switch mounted on the machine with which they have been combined.

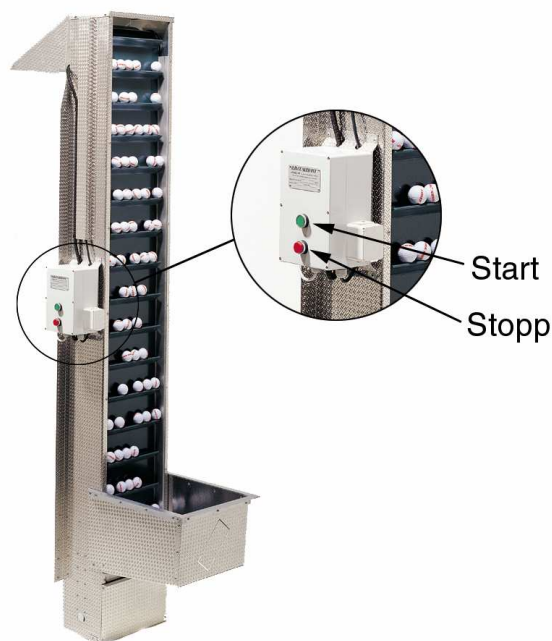

Figure 4: Location of the Start/Stop switch

4 Design and function

4.1 General

The machine is intended for the transportation of golf balls vertically, between different levels, and contains a conveyor belt. The conveyor belt runs between two rollers, one at the higher level and the other at the lower level. As the conveyor belt moves from bottom to top, it passes one or several ball ejection openings. The balls are loaded from the ball tray onto the belt and are carried between the loading place and the ball chute(s) on a number of ledges mounted horizontally from side to side of the conveyor belt.

The Range Servant Elevator has been designed in order to provide the customer with long lasting, functional, rational and economic golf ball management on the driving range.

4.1.1 Main components

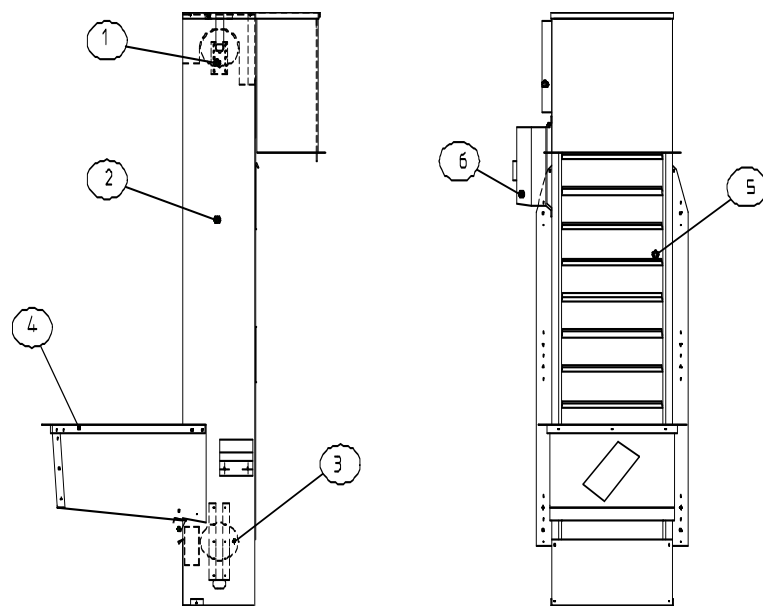

Figure 5: Elevator

Pos.	Designation
1	Motor
2	External panels
3	Adjustable drum
4	Ball tray
5	Conveyor belt
6	Enclosure

5 Maintenance

5.1 General

Range Servant provides accessories and original spare parts together with competent advice.

Maintenance carried out correctly minimises defects and ensures maximum service life and reliable operation. Any malfunctions are detected at an early stage and are therefore easily corrected. Regular maintenance minimises defects and equipment breakdown.

The following maintenance instructions only refer to the most common problems and their causes.

5.2 Periodical maintenance

5.2.1 Monthly

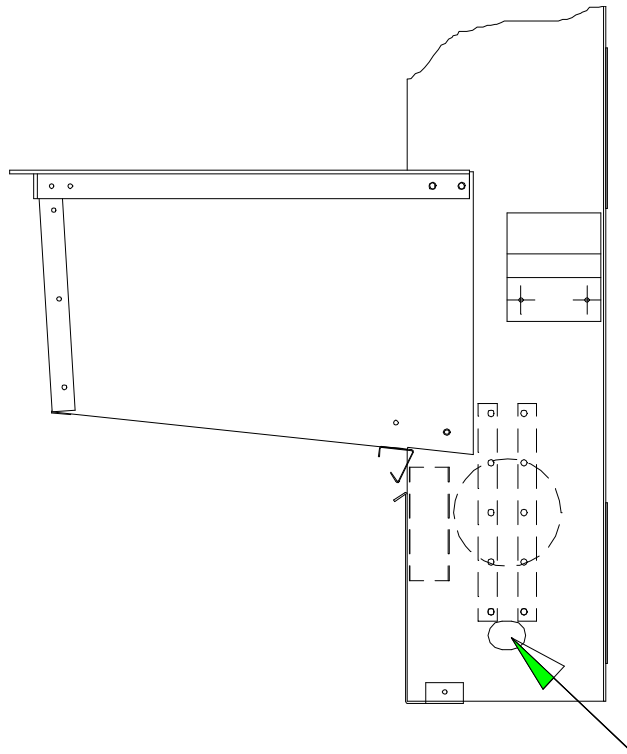

Figure 6: Tightening the belt

- Check that the belt is tightened and runs straightly. If the belt needs adjusting, this is done with the help of the bolts at the bottom of the elevator. See the arrow on figure Figure 6: Tightening the belt

5.2.2 Once every season

- Clean the photo cell monitoring the golf ball level.
- Remove dirt and grass from the conveyor belt.
- Remove dirt and grass from the ball tray.

5.3 Fault analysis and repair

5.3.1 General

The Elevator is very reliable but small problems may nevertheless arise for various reasons.

5.3.2 Fault analysis

The below chart will be helpful when you are trying to localise the fault:

SYMPTOM	POSSIBLE CAUSE	CORRECTIVE MEASURE
The belt is slipping.	→ The belt is not sufficiently tightened.	→ Check, and tighten if necessary.
The belt does not start moving.	→ The photo sensor is blocked by, for example, leaves.	→ Check, and remove if necessary
The belt is stuck.	→ A golf ball has got stuck in the belt.	→ Remove the ball.

Figure 7: Fault analysis for Elevator.

6 Installation

6.1 Unpacking and assembly

Where fully automated systems are concerned, please refer to the specific customer adjusted installation chart.

- I. Remove the packaging.
- II. Fasten the elevator to the ball dispenser, the hopper or the ditch with the screws delivered with the machine. See Figure 8: .

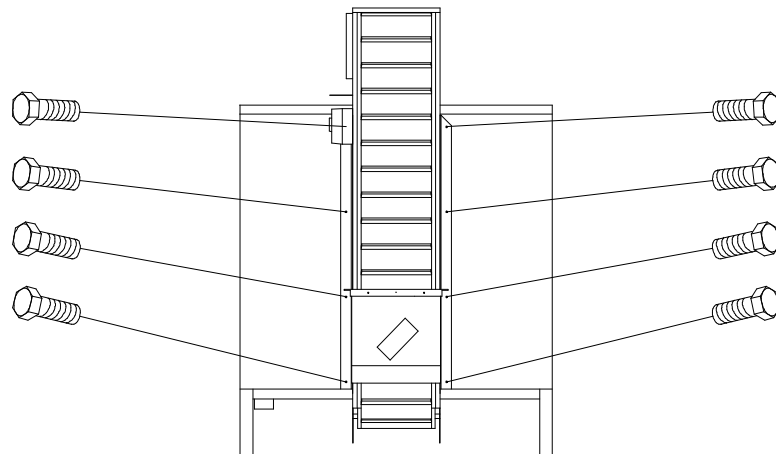

Figure 8: Fastening the elevator

- III. Mount the ball duct on the elevator using the screws delivered with the machine. See Figure 9: (1).

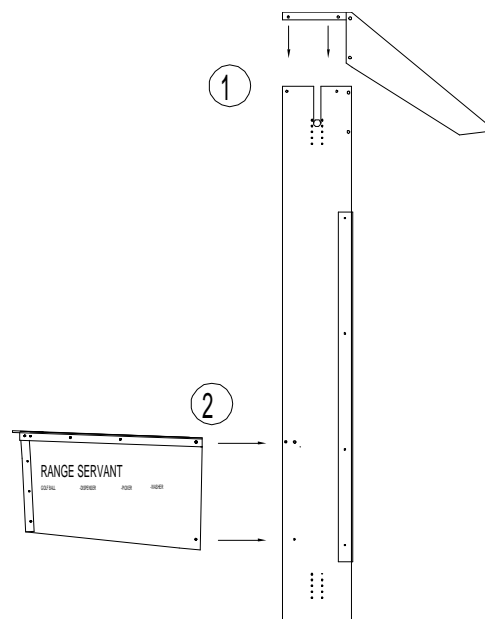

Figure 9: Mounting the ball duct

- IV. Mount the ball tray to the elevator using the enclosed screws. See Figure 9: Mounting at (2)

V. Connect the elevator to the mains supply.

6.2 Assembly of the elevator for BTW Dispenser

I. Remove the packaging.

II. Remove the bolt joint for the holder sheet and hang the elevator at the edge of the grating at the back side of the dispenser. The elevator will hang at the connection sheet with hook on the back side of the dispenser and be locked by the holder sheet to the grating.

III. Fasten the elevator to the ball dispenser by the bolt joint for the “Holder sheet” delivered with the machine. See Figure 8: .

Bolt joint Connection sheet w hook Holder sheet

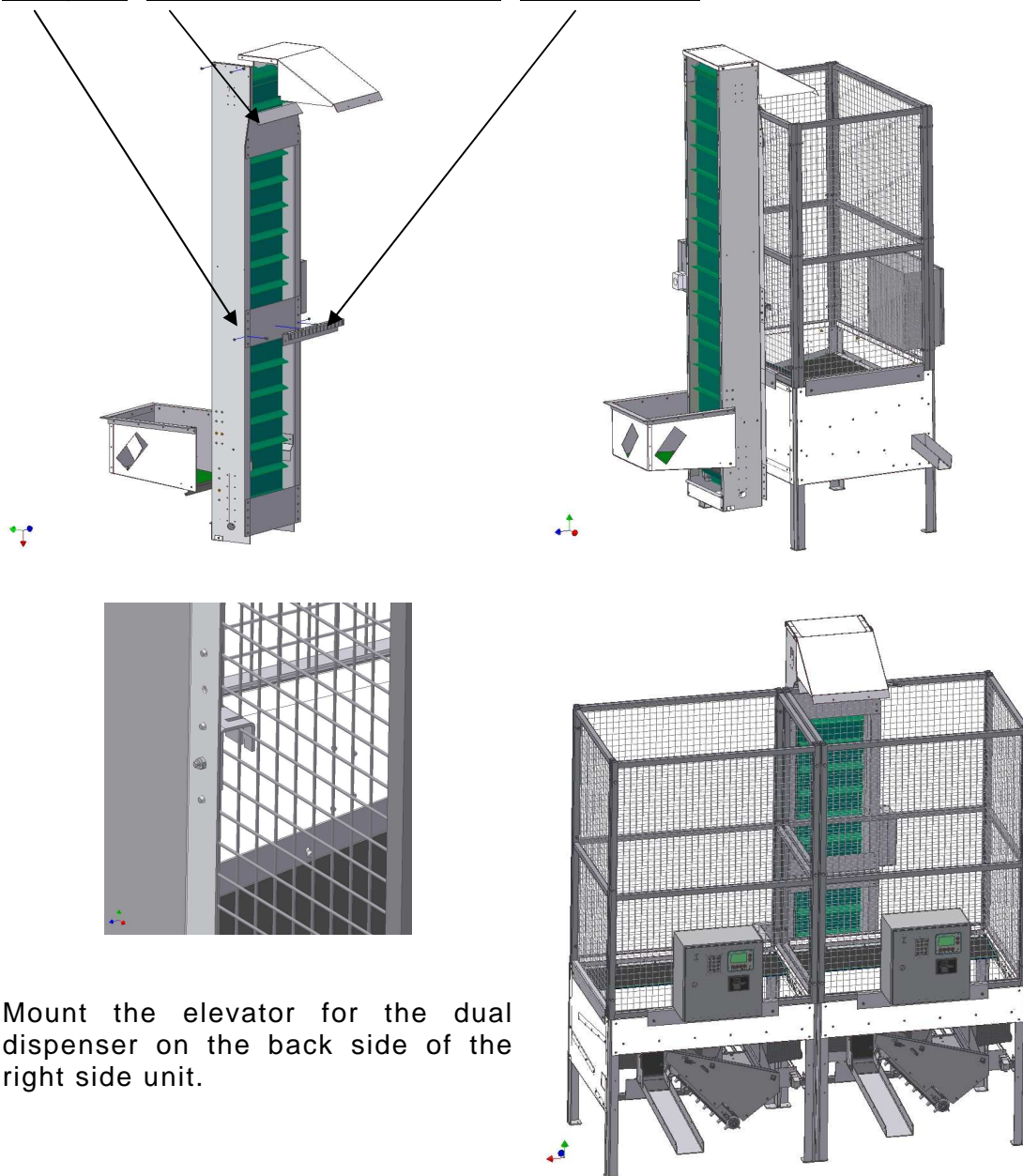

Mount the elevator for the dual dispenser on the back side of the right side unit.

Figure 10: Mounting the elevator for BTW dispense

7 Spare parts

7.1 Spare parts number

7.1.1 Elevator for machines with a flat top: RS-1.8/Ultima-1.4

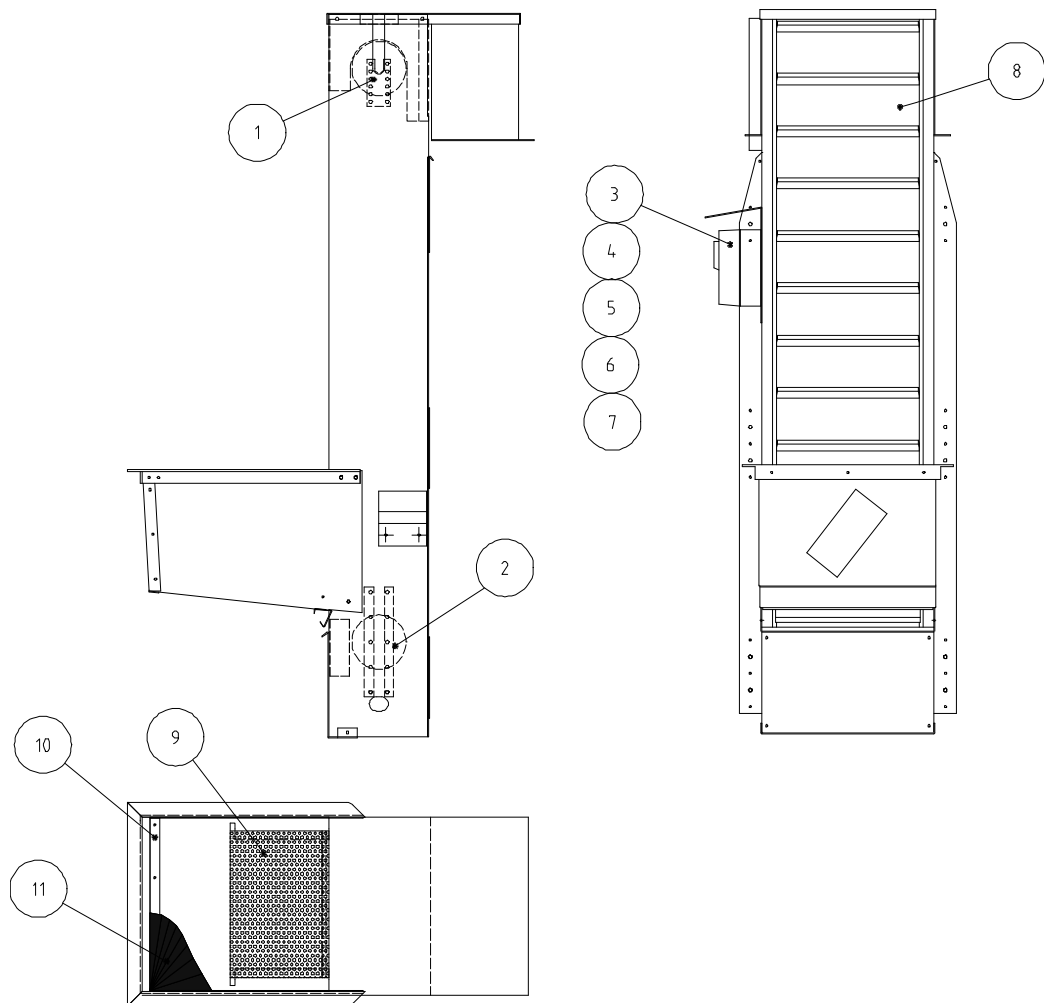

Figure 11: Elevator for machines with a flat top

Pos.	Part No.	Designation	Qty
1	40 0520	Motor, 230 V	1
2	40 0610	Adjustable drum	1
3	42 0250	Enclosure with overload protection	1
4	42 0365	Contactora 230 V	1
5	40 0235	Condenser, 6 μ f	1
6	42 0270	Photo cell amplifier, 230 V	1
7	42 0360	Relay 230 V	1
8	EGA0000	Conveyor belt, 1.4m	1
8	41 0650	Conveyor belt, 1.8m	1
9	401100	Ball stop	1
10	401010	Ledge	1
11	401000	Rubber mat	1

7.1.2 Elevator for machines with a conic top: RS-2.3/Ultima-2.1

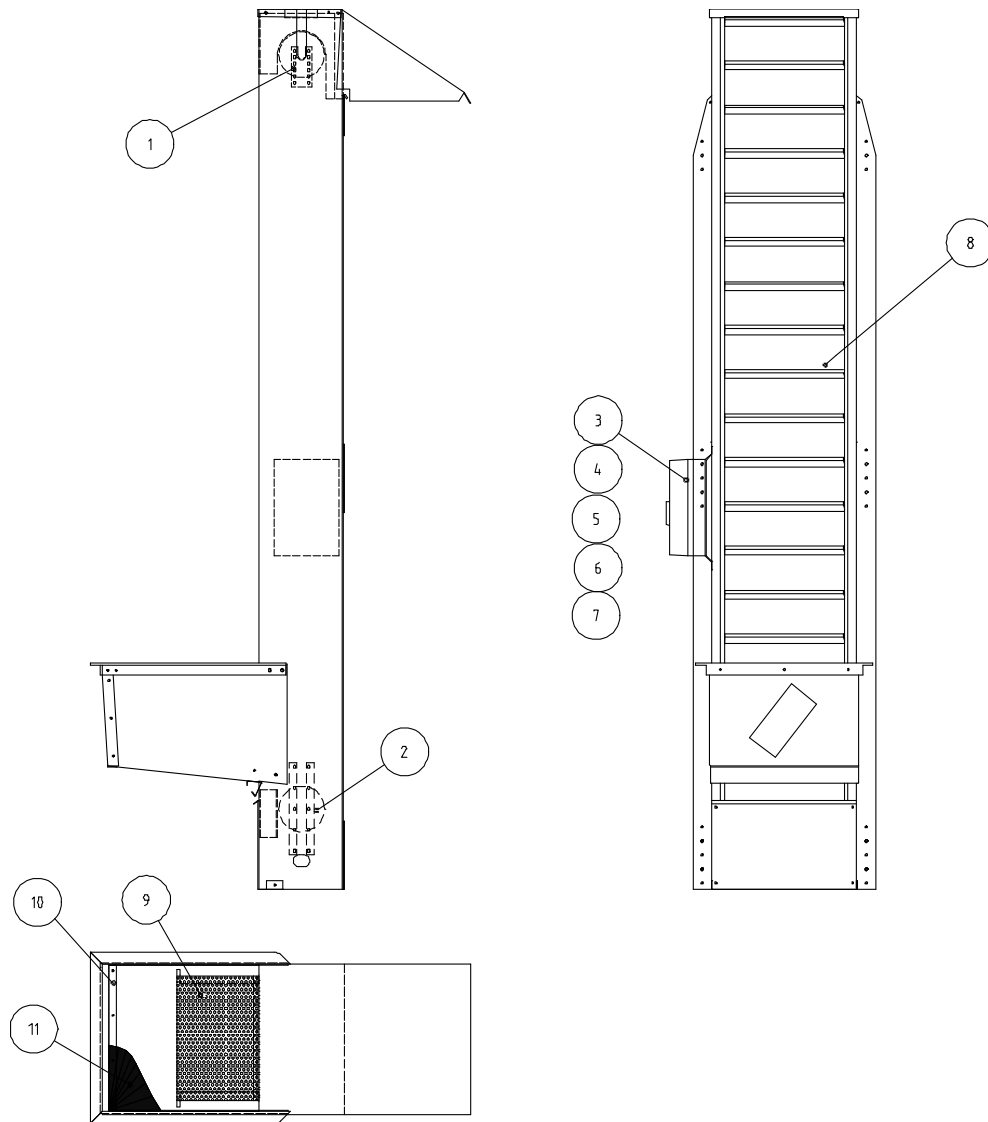

Figure 12: Elevator for machines with a conic top

Pos.	Part. No.	Designation	Qty
1	40 0520	Motor, 230 V	1
2	40 0610	Adjustable drum	1
3	42 0250	Enclosure with overload protection	1
4	42 0365	Contactora, 230 V	1
5	40 0235	Condenser, 6 μ f	1
6	42 0270	Photo cell amplifier, 230 V	1
7	42 0360	Relay 230 V	1
8	EHA0000	Conveyor belt, 2.1m	1
8	42 0650	Conveyor belt, 2.3m	1
9	401100	Ball stop	1
10	401010	Ledge	1
11	401000	Rubber mat	1

7.1.3 Elevator for BTW dispensers: BTW Ultima 9-30

The difference between the standard elevator 1.8m or 2.1m and the elevator for the BTW dispensers are using a different mounting device.

The Pos.12 “Connection sheet with hook”

and the Pos.13 “Holder sheet “

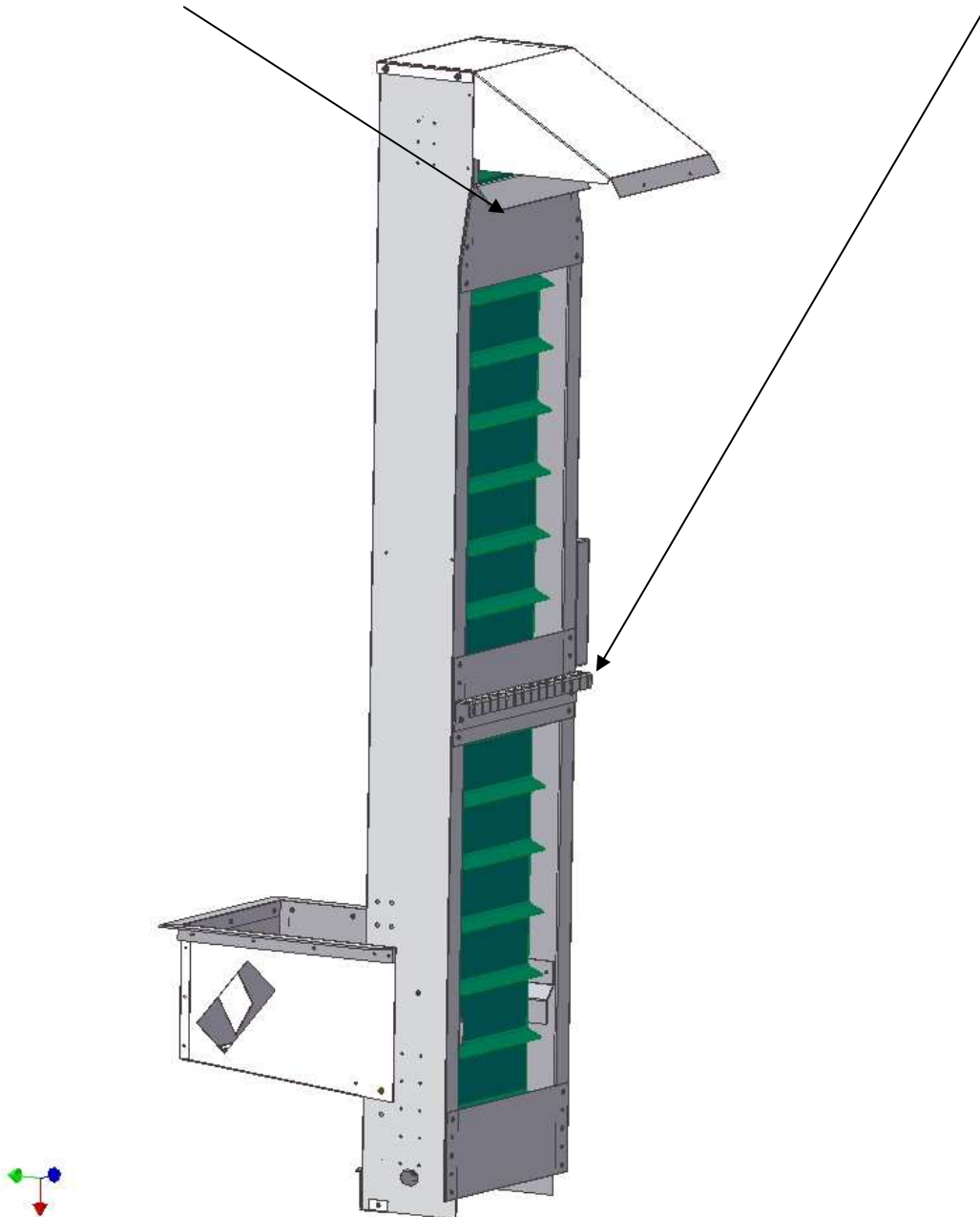

Figure 13: Elevator for BTW dispensers

Pos.	Part. No.	Designation	Qty
12	EHM0016	Connection sheet with hook	1
13	EHM0017	Holder sheet	1

7.1.4 Ditch-Elevator

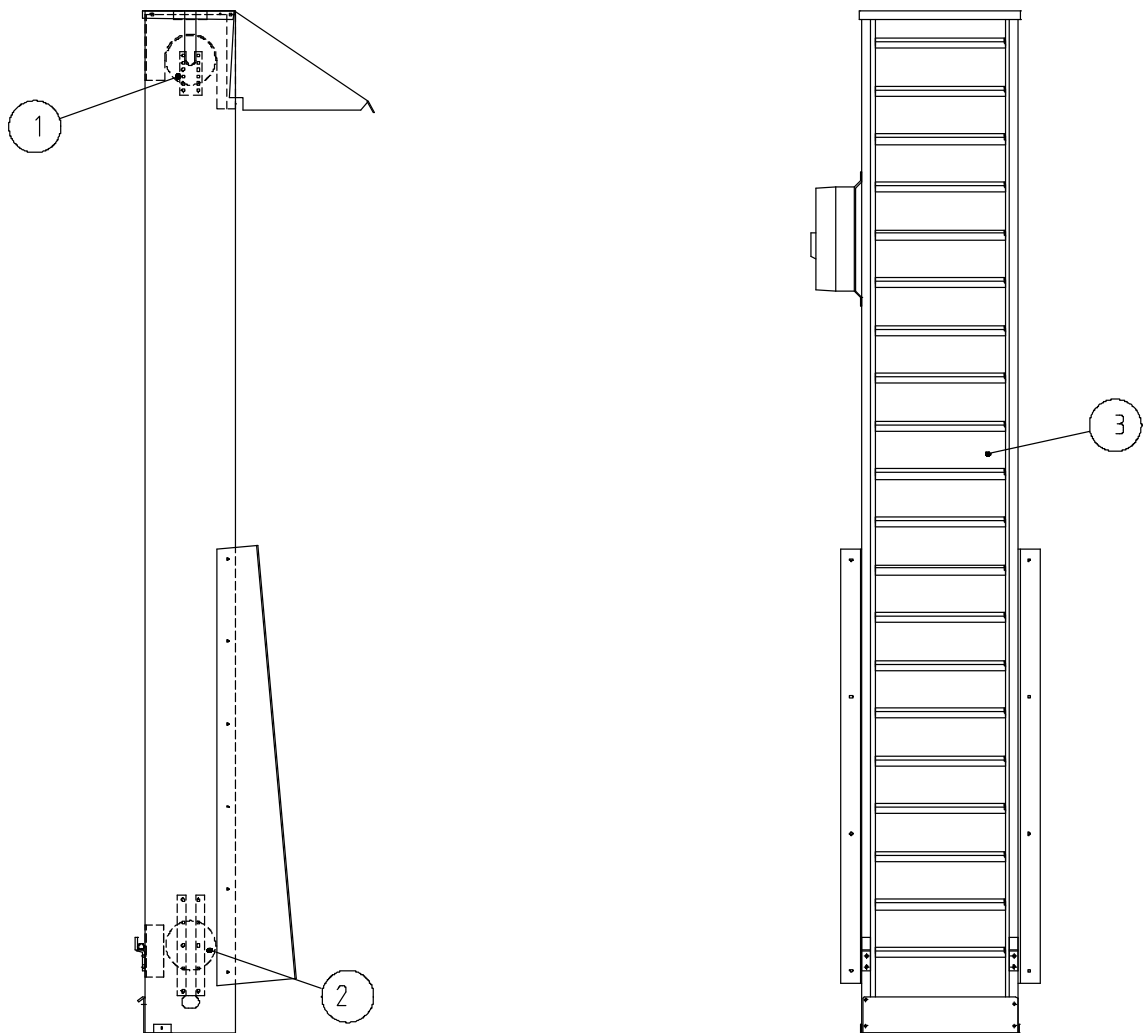

Figure 14: Ditch Elevator

Pos.	Part No.	Designation	Qty
1	EAA0001	Motor, 230 V, 3-phase	1
2	40 0610	Adjustable drum	1
3	42 0650	Conveyor belt, 2.3m ditch elevator	1

7.1.5 Multi-storey Elevator

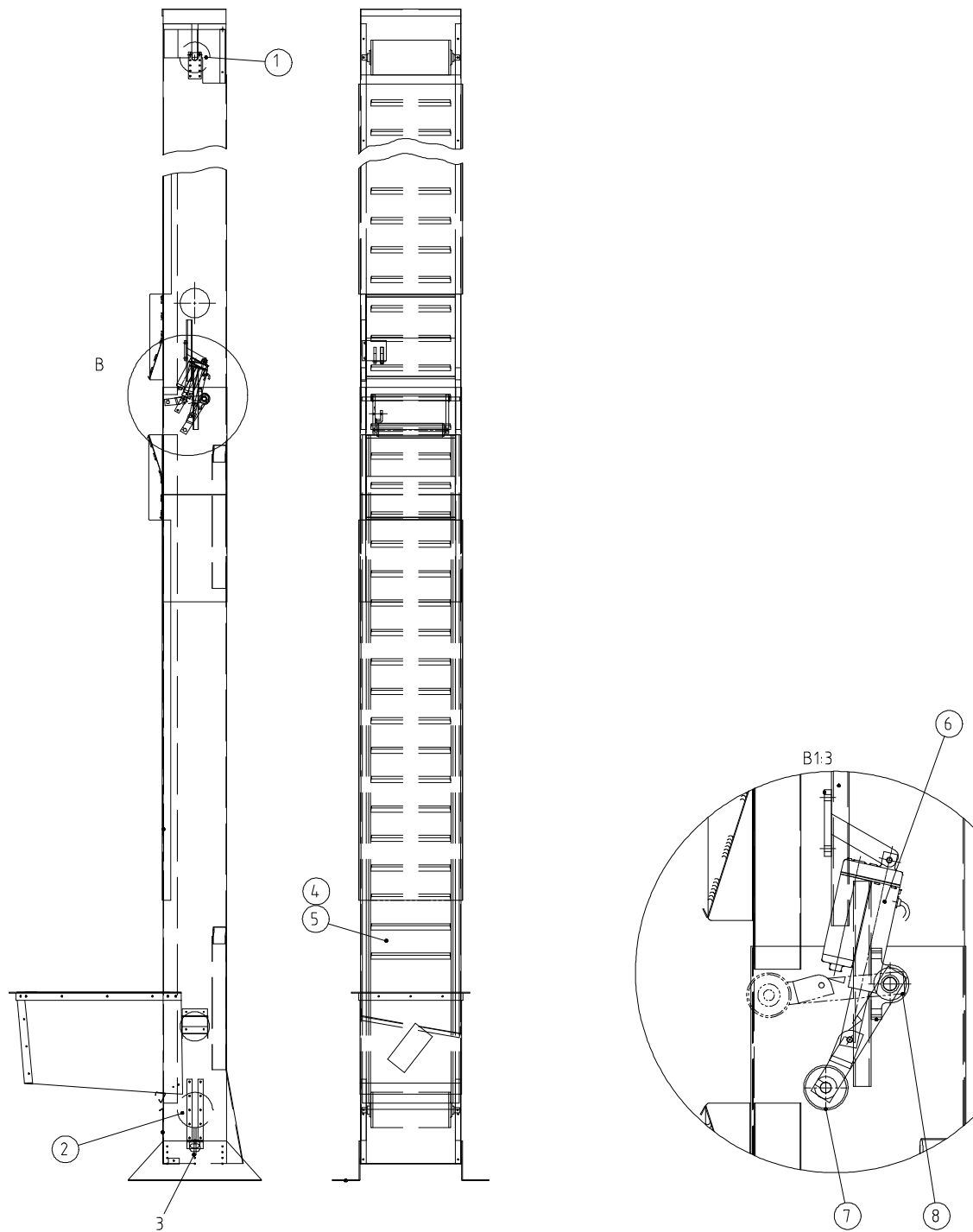

Figure 15: Multi-storey elevator

Pos.	Part No.	Designation	Qty
1	EDA0004	Motor	1
2	EDA0005	Adjustable drum	1
3	EDM0007	Counterstay, belt stretcher	2
4	EDA0001	Conveyor belt	1
5	45 0400	Ball ejection plate	X
6	45 0700	Piston	1
7	EDA0000	Roller, ball ejecting device	1
8	10 4650	Bearings	2

8 Retailers and representatives

The following list contains all the necessary information concerning the Range Servant representative closest to where you live.

The list is continuously updated on our home page <http://www.rangeservant.com>

8.1 Head Office

Sweden

Range Servant AB

Skallebackavägen 11

302 41 HALMSTAD

Telephone: +46 35 10 92 40

Fax: +46 35 10 82 20

E-Mail: sales@rangeservant.com

8.2 Your Sales Representative

