



ENGLISH

# *RANGE SERVANT*<sup>®</sup>

<http://www.rangeservant.com>

## **USER'S MANUAL**

### **BALL WASHER-1950**

### **BALL WASHER-1300**

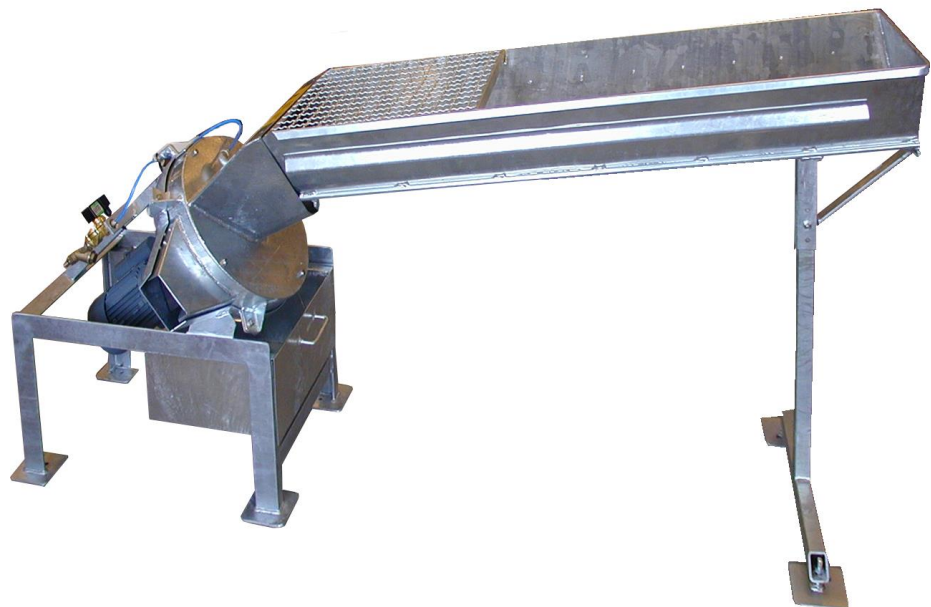

# TABLE OF CONTENTS

<b>1</b>	<b>General Information</b>	<b>4</b>
1.1	Preface	4
1.2	1.2 EC Declaration of Conformity	5
1.3	Description	6
1.3.1	Ball Washer	6
1.3.2	Ball Management System	6
1.4	Identification	6
1.5	Technical Specifications	7
<b>2</b>	<b>Safety</b>	<b>9</b>
2.1	General	9
2.2	Conformity with mandatory requirements	9
2.3	Remaining risks	9
2.4	Authorised use	10
2.5	Not authorised use	10
2.6	Emergencies	10
2.6.1	Fire	10
2.7	Operational reliability	11
<b>3</b>	<b>Operation</b>	<b>12</b>
3.1	Necessary qualifications	12
3.2	Operating the Ball Washer	12
3.2.1	Start and stop	12
<b>4</b>	<b>Design and function</b>	<b>13</b>
4.1	General	13
4.1.1	Main components BT 1950 and BT1300	14
<b>5</b>	<b>Maintenance</b>	<b>15</b>
5.1	Periodical maintenance	15
5.1.1	Monthly	15
5.1.2	Once every season	15
5.1.3	When necessary	15
5.2	Fault analysis and Repair	16
5.2.1	General	16
5.2.2	Fault analysis	16
<b>6</b>	<b>Installation</b>	<b>17</b>

<b>6.1</b>	<b>Unpacking and assembly</b>	<b>17</b>
6.1.1	BT 1950	17
6.1.2	BT 1300	19
<b>7</b>	<b>Spare parts</b>	<b>20</b>
<b>7.1</b>	<b>Spare parts numbers</b>	<b>20</b>
7.1.1	BT 1950	20
7.1.2	BT 1300	21
<b>8</b>	<b>Retailers and representatives</b>	<b>22</b>
<b>8.1</b>	<b>Head Office</b>	<b>22</b>
<b>8.2</b>	<b>Your Sales Representative</b>	<b>22</b>

Title:	Br07bt1950-E.doc
Prepared by:	Johan Carlsson
Date:	19/08/2014
Antal ord:	3230
Version:	6

# 1 General Information

## 1.1 Preface

We congratulate you to your new Range Servant machine. You have made a good choice! Not only have you chosen an excellent state-of-the-art Ball Washer with little demands on maintenance but you have also chosen quality. Quality is ensured with the help of modern production techniques, carefully chosen materials and the responsible workmanship of our staff.

**The purpose of the User's Manual is to make the user familiar with the machine and its use in different situations and for different types of work!** This Manual includes all the drawings and diagrams necessary for putting the machine into operation and for carrying out maintenance, inspections, function tests and repairs. It also contains useful information about safety.

**Study the User's Guide carefully before using the machine.** If these instructions are not followed, persons using the machine might be injured or the equipment itself be damaged. In many cases, following the instructions is a necessary condition for Range Servants' warranty to be applicable. Every person operating the machine must read these instructions.

No part of this publication may be reproduced without the written authorisation of Range Servant.

The Ball Washer has a one-year warranty. Study the warranty conditions carefully and keep them in a safe place. If you have any questions, or if problems should arise, please contact your Range Servant representative.

### **ONE YEAR WARRANTY**

Range Servant AB hereby offers a warranty of one year from the date of shipment from the factory on material and function of the RANGE SERVANT product specified in this Manual. This engagement applies to repaired or replaced components for a period of three months. This undertaking only applies to the original purchaser. Furthermore, it is limited to the components that the manufacturer finds to be faulty when inspected. Repairs or replacement of components shall be carried out by a representative authorised by the manufacturer. The manufacturer further guarantees that the equipment supplied corresponds to the product description issued. **THE UNDERTAKINGS SPECIFIED IN THIS AGREEMENT CONSTITUTE THE MANUFACTURER'S SOLE OBLIGATION TOWARDS THE PURCHASER. THE MANUFACTURER DECLINES ALL RESPONSIBILITY FOR ANY FORM OF PROMISE OUTSIDE THE FRAMEWORK OF THIS GUARANTEE CERTIFICATE.** The manufacturer also declines all responsibility for promises that might have been made by a third party in conjunction with the sale. The guarantee contract does not apply to equipment that has been repaired or has had components replaced by persons/companies not authorised by the manufacturer. The manufacturer's guarantee is void if equipment has been incorrectly used, damaged by lack of maintenance / accident or has not been handled in accordance with the written user's manual supplied on delivery. Finally, the manufacturer is exempted from financial responsibility for any kind of injury which might arise in conjunction with the sale and repair of equipment, and from injury suffered by third parties in conjunction with use of the product.

## 1.2 1.2 EC Declaration of Conformity

In accordance with the Machine Directive 89/392/EEC, annex 2A.

**The Manufacturer:**

***RANGE SERVANT***<sup>®</sup>

Range Servant AB  
Skallebackavägen 11  
SE- 302 41 HALMSTAD  
Sweden

**The Representative:**

*(To be filled out by a representative established within the EU)*

.....  
*Company*

.....  
*Address*

.....  
*Telephone*

**Declare that:**

.....  
*Machine*

.....  
*Type*

.....  
*Serial no., manufacturing no. etc.*

A) is in conformity with Council Directive 89/392/EEC of 14 June 1989 concerning approximation of the laws of the Member States relating to machines in particular as referred to in Annex I to this Directive concerning essential health and safety requirements in connection with the design and manufacture of machines, as amended by Council Directive 91/368/EEC of 20 June 1991 on the amendment of Directive 89/392/EEC concerning approximation of the laws of the Member States relating to machines;

B) *(if applicable)*  
are manufactured in accordance with the following regulations, directives etc.: .....

C) *(if the requirements under A have been fulfilled)*  
that the harmonised standards 292-1, 292-2 and 292-2A (or parts thereof) have been applied

D) *(if applicable)* are manufactured according to the following national standards and technical specifications:.....

Halmstad,

.....  
*Date*

Elvis Knez  
President

.....  
*Signature*

## 1.3 Description

### 1.3.1 Ball Washer

The Ball Washer can be used individually or be included in an automated system, the Range Servant Ball Management system.

The Range Servant Ball Washers have proven themselves to be the most reliable ball washers on the market. They are robust and all models are equipped with powerful motors. With no failure-prone bearings or belts maintenance is negligible.

### 1.3.2 Ball Management System

Range Servant can deliver a complete, flexible Ball Management System adaptable to any kind of driving range requirements. The Ball Dispenser can be combined with the work-efficient, environment friendly Ball Washer. The Ball Washer in turn can be connected to the Elevator, the Conveyor Belt or the Blower for the transport of clean, undamaged balls from Washer to Dispenser. The system also includes a Ball Picker, a machine picking up used balls from all over the driving range. Thus the circle is closed and manual work has been reduced to a minimum.

By applying our extensive know-how to the specific problems of every driving range we are able to offer tailor-made solutions.

## 1.4 Identification

When contacting Range Servant, please identify your machine with the help of the information contained in the identification plate. The identification plate is well visible and firmly attached and contains the following information:

- Name and address of the manufacturer
- CE-marking
- Designation of series or type of machine
- Serial no., if any
- Year of manufacture

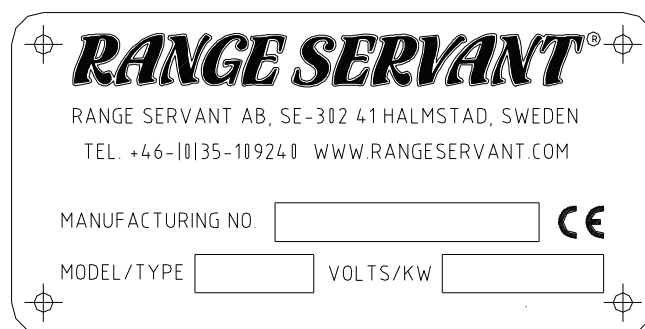

Fig. 1: Product identification plate

## 1.5 Technical Specifications

General	BT-1950	BT-1300
Washing capacity [balls/min]	400	200
Ball tray capacity [quantity of balls]	1000	1000
Motor [kW]	0,55	0,37
Motor Oil	Mineral oil ISO VG220	Mineral oil ISO VG220
Voltage [Volt, 50 Hz]	230	230
[Volt, 60 Hz]	115	115
Water consumption [l/min] /([gallon/min])	4 (1)	4 (1)
Water connection	R1/2"	R1/2"
Water pressure [bar] /([psi])	1.96-12.0 (28.4 -174)	1.96-12.0 (28.4 -174)
Avloppsanslutning, diameter [mm] /([in])	50 (2)	50 (2)
<b>Measure:</b>		
Hight [mm] /([in])	956 (37.6)	942 (37.1)
Width [mm] /([in])	560 (22.0)	560 (22.0)
Length [mm] /([in])	1887 (74.3)	1875 (73.8)
<b>Operating Conditions:</b>		
Operating Temperature [°C] /([°F])	+2 - +50 (+35- +122)	+2 - +50 (+35- +122)

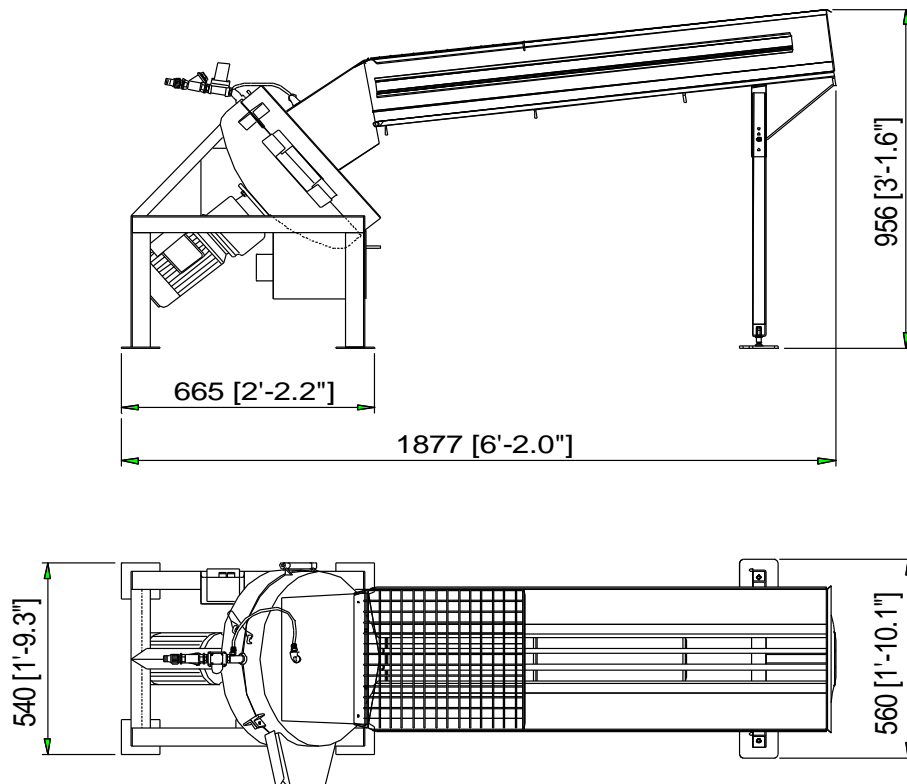

Figure 2: Ball Washer BT1950

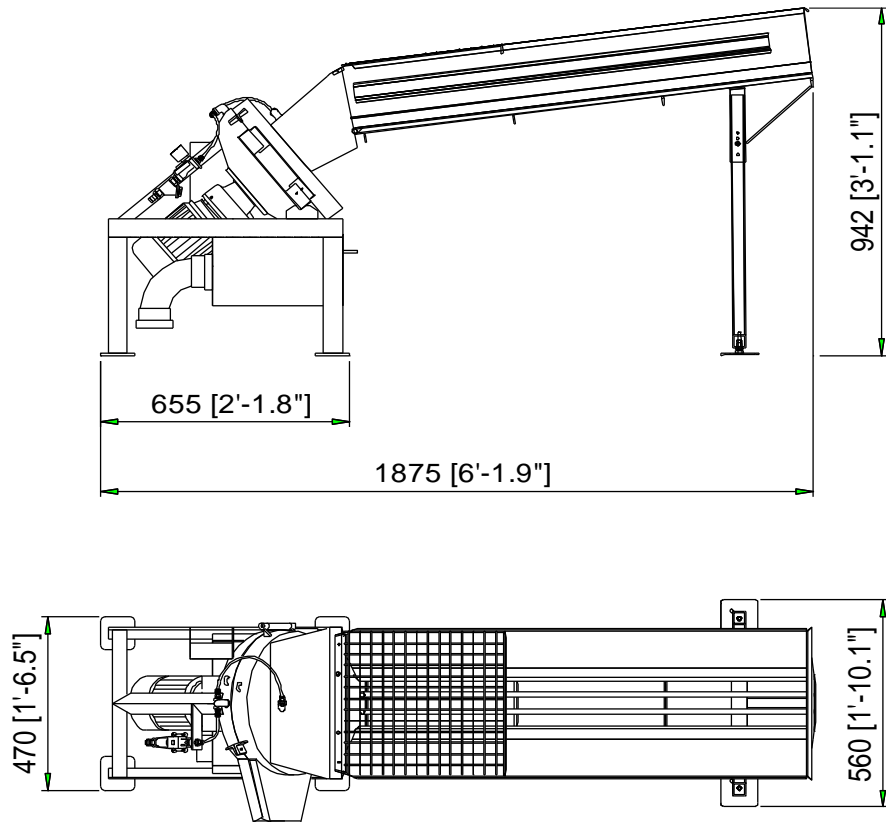

Figure 3: Ball Washer BT1300

The level of airborne noise has been measured for an identical machine under normal operating conditions.

The values indicate the sound pressure level measured 1 m from the surface of the machine and 1,6 m from the floor or access platform.

Sound Pressure				
Sound pressure at the machine (dB, Lin)	XX	XX	XX	XX
Sound pressure at the machine (dB, A)	XX	XX	XX	XX

*The manufacturer reserves the right to make alterations without prior notice.*

*Patents and patent applications:*

*SE 8700873-6, US 4881287, DE 3867656-7, ES 2028367, FR 88850072.5, GB 88850072.5, IT 88850072.5, NL 88850072.5*



## 2 Safety

### 2.1 General

Safety measures are a combination of measures taken by the manufacturer when designing and building the machine and measures that have to be taken by the user. The machine has been designed to function for its intended purpose. It has been designed and manufactured so that configuration and maintenance work can take place with the least possible risks to the operator, provided such work is carried out according to the instructions laid down in the User's Manual. The objective of the safety measures is to eliminate all accident risks during the operational life of the machine which also includes the assembly and dismantling of the machine, including any hazards arising as a consequence of such abnormal circumstances as can be anticipated.

Accessories and spare parts that have not been approved by Range Servant can lead to personal injuries and/or equipment damage and affect the operational reliability of the machine. For the sake of safety you should therefore exclusively use accessories and original Range Servant spare parts recommended by Range Servant. Such accessories and spare parts are specially intended for the machine and are approved by us with regard to safety.

All Range Servant retailers keep accessories and spare parts at your disposal and are happy to give you competent advice. They also have the technical qualifications necessary for installing your machine and are informed about what technical changes are authorised.

Damage caused by the use of accessories and spare parts not having been approved by Range Servant as well as damage due to un-authorised technical alterations are not covered by the guarantee.

### 2.2 Conformity with mandatory requirements

The Range Servant ball management machines fulfil the personal safety requirements of the EU Machine Directive 89/392/EEC as amended by Directives 91/368/EEC, 93/44/EEC and 93/68/EEC, with a special reference to Annex I of the Directive concerning essential health and safety requirements in connection with the design and manufacture of machines, as amended by Directive 91/368/EEC. Furthermore the harmonised standards 292-1, 292-2 and 292-2A (or parts thereof) have been applied.

The electrical equipment fulfils the safety provisions laid down in the EU low voltage directive 73/23/EEC, as amended by directive 93/68/EEC.

### 2.3 Remaining risks

There are warning signs serving as a reminder and warning to the user of any remaining risks, i.e. risks that we have not been able to eliminate, or sufficiently minimise, in our design and against which technical safety measures do not provide complete, or sufficient, protection. The warning signs shall be written in the local language and, upon request, in the language understood by the respective operator. The signs are yellow with black characters. They are big enough to be readable from a distance of three meters.



Figure 4: Warning sign on front hatch

- Always disconnect the power supply to the machine before carrying out maintenance or service work. The mains switch is located in the lower right hand corner of the printed circuit board.
- Mechanical or electrical alterations may only be undertaken after consultation with Range Servant.
- Never put your hands into the ball washer when it is working.
- Only use clean water without any additions.
- If the machine is used by temperatures below 2°C, there is a risk that the water valve and water hoses freeze. In order to avoid this, always disconnect the water supply and check that the machine is empty of water when temperatures are approaching zero.

## 2.4 Authorised use

The machine may only be used for washing golf balls. It may only be used in compliance with the instructions contained in this Manual.

## 2.5 Not authorised use

Using accessories or spare parts not recommended by Range Servant might cause personal injury and/or equipment damage and affect the operational reliability of your machine. For safety reasons, only use components recommended by us. They are intended for your machine, they have been chosen for safety reasons and they are approved by the manufacturer.

Damage caused by the use of accessories and spare parts that are not approved by Range Servant, or damage due to un-authorised technical alterations are not covered by the guarantee.

## 2.6 Emergencies

### 2.6.1 Fire

Water shall be used as an extinguisher in the event of fire, except if the fire is located in the electric equipment, where a carbon dioxide extinguisher must be used.

## **2.7 Operational reliability**

For trouble-free operation and long service life the instructions below should be followed:

- Place the machine on a firm and level foundation.
- Place the machine under the roof.
- Bolt the machine to the foundation to keep it from being unintentionally moved from its correct location.

## 3 Operation

### 3.1 Necessary qualifications

The technical design and function of the machine is such that the person carrying out service and maintenance work must have the necessary qualifications. He shall have attended a documented training course consisting of the study of the User's Manual, at the end of which he must have well understood its contents.

If the person is absent from work for more than three months, training must be renewed.

### 3.2 Operating the Ball Washer

#### 3.2.1 Start and stop

The Ball Washer is started and stopped by means of the Start/Stop knob.

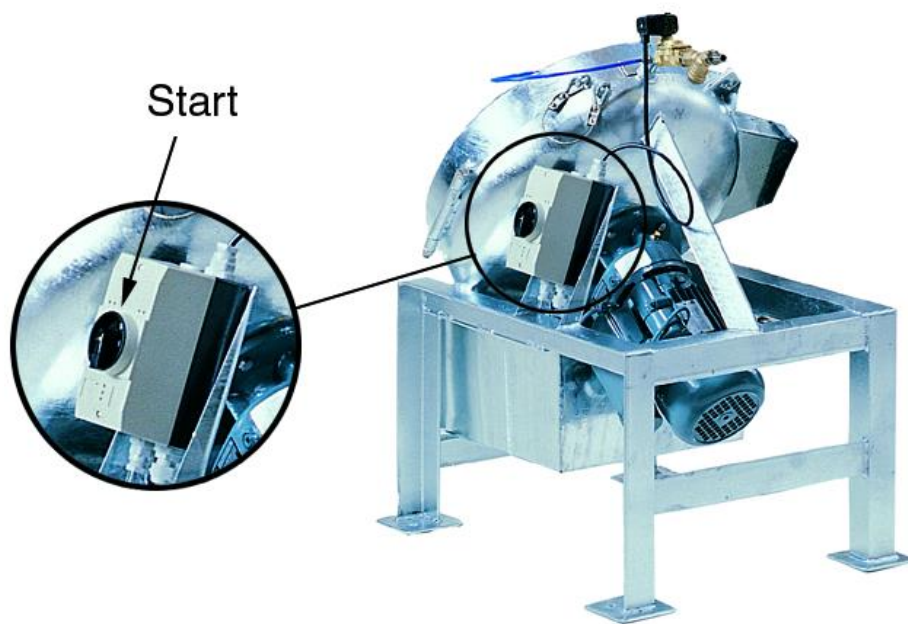

Figure 5: Starting the Ball Washer.

## 4 Design and function

### 4.1 General

The machine is intended for the cleaning of golf balls. The Ball Washer consists of two discs arranged opposite each other with a space in between. The facing surfaces of the discs are one equipped with brushes and the other with rubber. The distance between the discs is smaller than the ball diameter. The lower disc rotates while the upper disc is stationary. This produces the cleaning effect. The golf balls are fed into the space between the brushes through a opening placed centrally in the upper disc. Both discs are arranged in a container with a bowl-shaped bottom and a bowl-shaped dividing wall. In the middle of the dividing wall is an opening that corresponds to the central opening in the upper, stationary disc.

The rotating disc is fastened to an axle going through the central opening. The axle is connected to a motor rotating the axle and the lower disc to which it is attached.

The axle is equipped with a device by means of which the objects are forced in a spiral shaped course from the center towards the sides of the lower disc and further on through the outlet.

The spray nozzles spray the golf balls with water before, during and/or after the cleaning process.

The Range Servant Ball Washers have been designed in order to provide our customers with a functional, rational and economic ball management system that lasts for a long time.

#### 4.1.1 Main components BT 1950 and BT1300

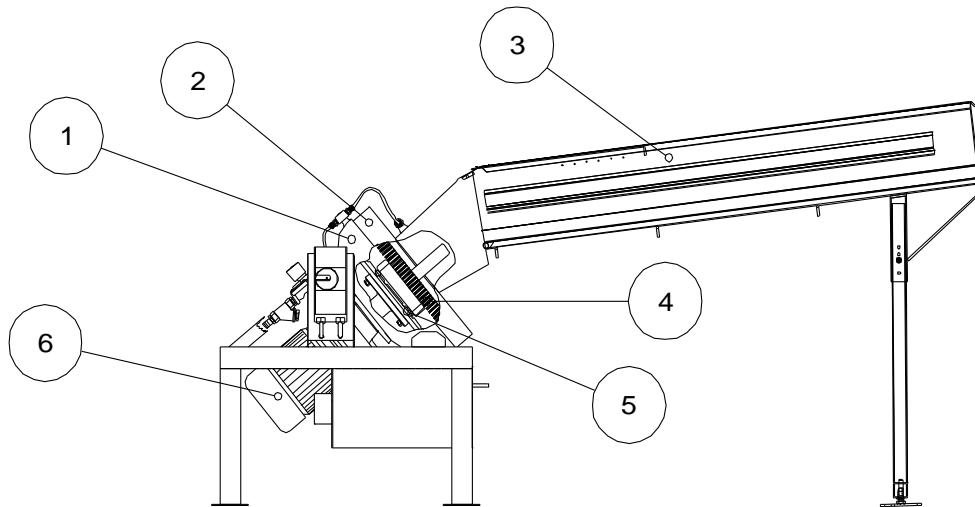

Figure 6: Ball Washer, side view

Pos.	Designation
1	Lower part
2	Upper part
3	Ball tray
4	Brush
5	Disc
6	Motor

# 5 Maintenance

Range Servant provides accessories and original spare parts together with competent advice.

Maintenance carried out correctly minimises defects and ensures maximum service life and reliable operation. Any malfunctions are detected at an early stage and are therefore easily corrected. Regular maintenance minimises defects and equipment breakdown.

The following maintenance instructions only refer to the most common problems and their causes.

## 5.1 Periodical maintenance

### 5.1.1 Monthly

In order to obtain optimal cleaning results and operating economy, the Ball Washer should be opened and cleaned inside once every month. To open the washer, remove the ball tray and loosen the screws holding together the upper and lower part of the washer. Then clean it.

### 5.1.2 Once every season

Remove the dirt sieve (no: 10 510) and clean it.

Check the gear box oil level. Top up, if necessary.

### 5.1.3 When necessary

Empty the dirt box located under the washer.

## 5.2 Fault analysis and Repair

### 5.2.1 General

The Elevator is very reliable but problems may nevertheless arise for various reasons.

### 5.2.2 Fault analysis

The below chart may be helpful when you are trying to localize a fault.

SYMPTOM	POSSIBLE CAUSE	CORRECTIVE CORRECTIVE
The ball washer does not let out any balls.	<ul style="list-style-type: none"> <li>➡ Dirt or other debris has got stuck in the machine.</li> </ul>	<ul style="list-style-type: none"> <li>➡ Remove any debris stuck in the machine.</li> </ul>
	<ul style="list-style-type: none"> <li>➡ The brush is worn and needs to be changed.</li> </ul>	<ul style="list-style-type: none"> <li>➡ Check the distance between the brush (no. 22 111) and the rubber disc (no. 22 065). If the distance is greater than 35-37 mm the brush is likely to be worn</li> </ul>
No water arrives in the washer.	<ul style="list-style-type: none"> <li>➡ The water supply has been closed off.</li> </ul>	<ul style="list-style-type: none"> <li>➡ Check that the water supply is opened.</li> </ul>
	<ul style="list-style-type: none"> <li>➡ The water valve is defect.</li> </ul>	<ul style="list-style-type: none"> <li>➡ Check the water valve (no. 10 530) by listening to the valve when the washer is started. A clicking sound must be heard, else the valve is defect and must be changed.</li> </ul>
The washer does not stop/start	<ul style="list-style-type: none"> <li>➡ Something has got stuck in the washer.</li> </ul>	<ul style="list-style-type: none"> <li>➡ Open the washer and check for rocks, pieces of rock or similar objects. Remove.</li> </ul>

Figure 7: Fault analysis for Ball Washer



## 6 Installation

### 6.1 Unpacking and assembly

#### 6.1.1 BT 1950

- I. Remove the packaging.
- II. Place the washer on level ground.
- III. Fasten the ball tray to the washer body with the two enclosed screws.. See Figure 8 at (A).
- IV. Screw all six feet to the foundation. See Figure 8: Assembly of BT 1950 at (B).

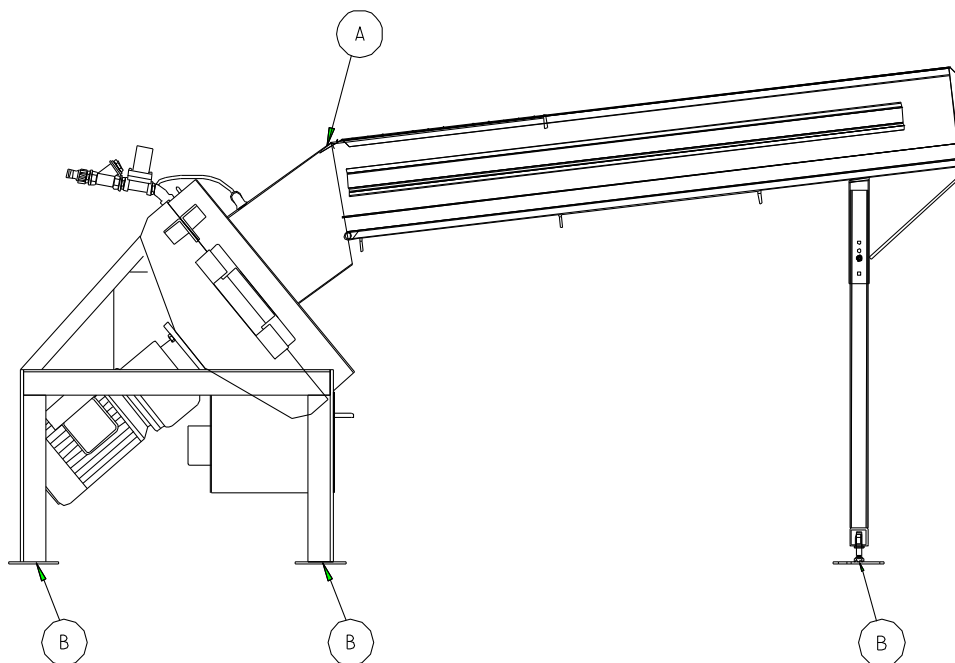

Figure 8: Assembly of BT 1950

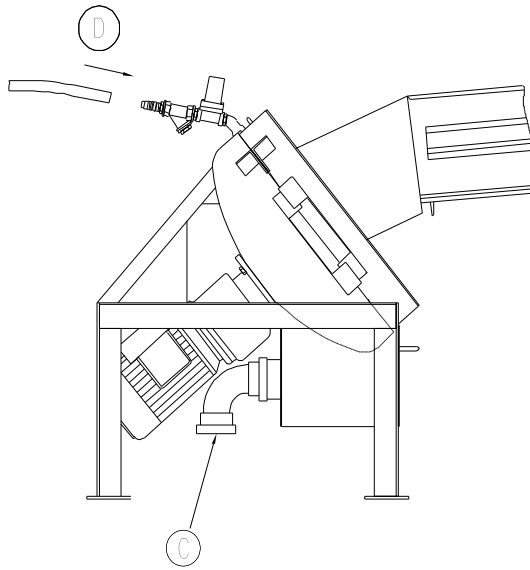

Figure 9: Mounting the washer

- V. Press the enclosed curved waste-water pipe as far as possible onto the drain connection of the dirt box. Connect the other end of the waste water pipe as suitable to the existing drain. See Figure 9: Mounting the washer at (C)
- VI. Connect a ½" water hose between the water connection nipple and a water tap. Open the tap completely. See Figure 9: Mounting the washer at (D)
- VII. Connect the machine to an earthed 230 V wall socket.
- VIII. **Start** the machine **before** adding the balls and **do not stop** until the machine is completely empty of balls.

### 6.1.2 BT 1300

- I. Remove the packaging.
- II. Place the ball washer on level ground.
- III. Fasten the ball tray to the washer body with the two enclosed screws. See Figure 10 at (A).
- IV. Screw all six feet to the foundation. See figure 10 at (B).

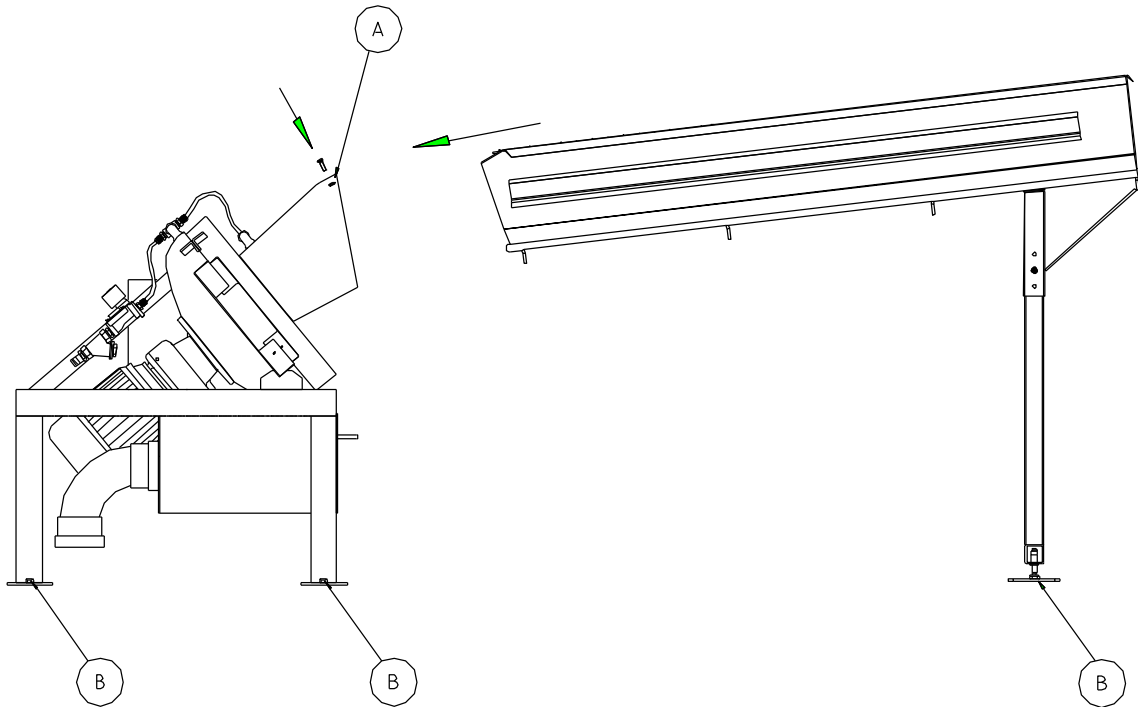

Figure 10: Assembly of BT 1300

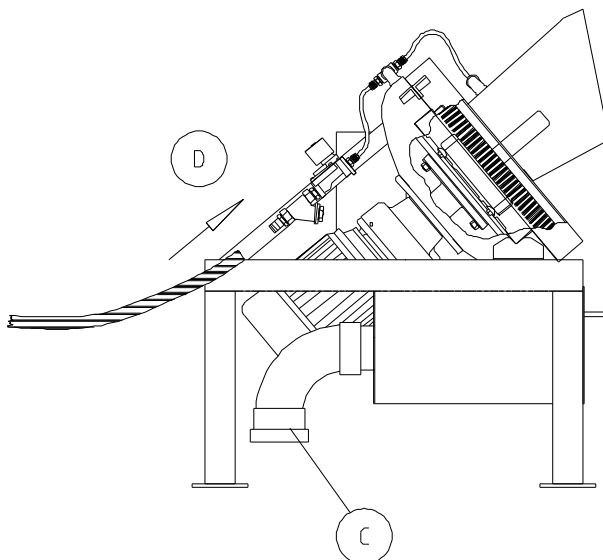

Figure 11: Mounting the washer

- V. Press the enclosed curved wastewater pipe as far as possible onto the drain connection of the dirt box. Connect the other end of the wastewater pipe in a suitable manner to the existing drain. See Figure 9: Mounting the washer at (C)
- VI. Connect a ½" water hose between the water connection nipple and a water tap. Open the tap completely. See Figure 9: Mounting the washer at (D)
- VII. Connect the machine to an earthed 230 V wall socket.
- VIII. **Start** the machine **before** adding the balls and **do not stop** until the machine is completely empty of balls.

## 7 Spare parts

### 7.1 Spare parts numbers

#### 7.1.1 BT 1950

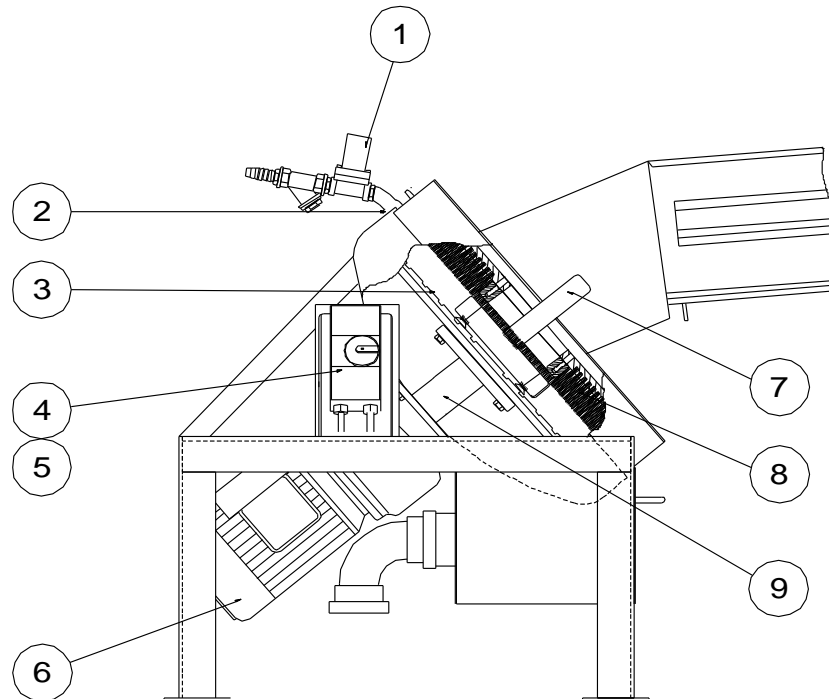

Figure 12: Ball Washer BT 1950, side view

Pos.	Part No.	Designation	Qty
1	10 5300	Complete water valve 230V	1
2	22 0170	Water nozzle, BPM12	1
3	22 0650	Rubber disc	1
4	93 0172	Motor protection 230V	1
5	93 0176	Enclosure, motor protection	1
6	20 0800	Complete motor 230V	1
7	WBM0040	Wing BT1950 NEW complete	1
8	221100	Brush, incl. plastic ring	1
9	22 0600	Flange	1

## 7.1.2 BT 1300

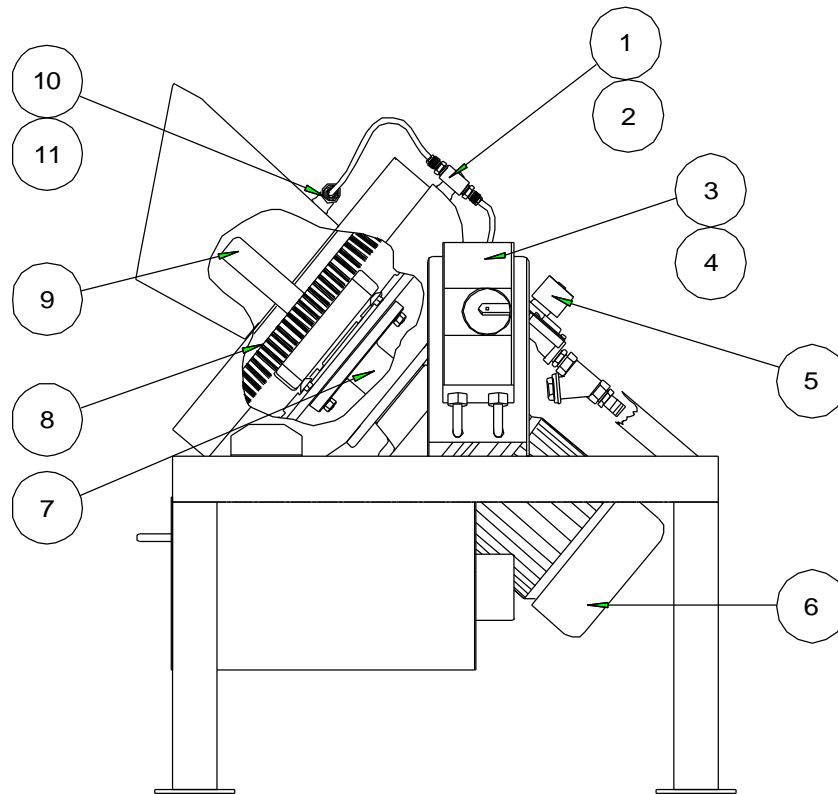

Figure 13: Ball Washer BT 1300, side view

Pos.	Part No.	Designation	Qty
1	WGA0001	T-fitting	1
2	22 0993	Slip-on fitting 1/8	1
3	93 0172	Motor protection 230 V	1
4	93 0176	Enclosure for motor protection	1
5	105 300	Complete water valve 230 V	1
6	WGA0003	Complete motor 230 V	1
7	WGM0013	Flange	1
8	WGM0014	Brush, incl plastic ring	1
9	WGM0042	Wing BT1300 NEW complete	1
10	22 0160	Curved pipe 45°	1
11	22 0993	Slip-on fitting 1/4	1

## 8 Retailers and representatives

The following list contains all the necessary information concerning the Range Servant representative closest to where you live.

The list is continuously updated on our home page <http://www.rangeservant.com>

### 8.1 Head Office

#### Sweden

##### Range Servant AB

Skallebackavägen 11

302 41 HALMSTAD

Telephone: +46 35 10 92 40

Fax: +46 35 10 82 20

E-Mail: [sales@rangeservant.com](mailto:sales@rangeservant.com)

### 8.2 Your Sales Representative

